



Subsea Connectors

Burton

Electro Oceanic

 **COOPER** Interconnect



Solutions You
Can Trust In
Challenging
Conditions

Subsea Connectors



Burton 5500 Series

Dry Mate - Pins in Receptacles and Sockets in the Plugs

Overview / Configurations.....	4-7
Contact Arrangements.....	8-9
High Voltage.....	10
PBOF and Accessories.....	11-12

Burton 6600 Series

Dry Mate - Sockets in the Receptacles and Pins in the Plugs

Overview / Configurations.....	14-17
Contact Arrangements.....	18-19
High Voltage.....	20
Accessories.....	21

Burton 5400 Series

High Pressure Penetrators.....	22-23
--------------------------------	-------

Burton Ethernet 5500 and 6600 Series

Dry Mate - Combined Ethernet and Power or Pure Ethernet Solutions.....	24-25
--	-------



Burton SC Series

Wet Mate - Rugged A, B, and C Size Standard Circular Connectors.....26-33

Electro Oceanic Series

Underwater Pluggable

Series 51 Male and Female Connector Plugs.....34-35

Series B51 Male and Female Connector Plugs (Accepts Locking Sleeve).....36-37

Series 53 Male and Female Connector Receptacles 38-39

Series B53 Male and Female Receptacles (Accepts Locking Sleeve).....40-41

Series 59 Male/Female Right Angle Receptacles.....42

Series 510 & 52 Two-Pin Male/Female.....43-44

Series 610 Magnetically Operated Switch.....45

Series 41 Penetrators.....46-47

Junction Boxes and Locking Sleeves.....48-49

Series 56 Miniature Connectors and WP Series.....50-52

Capabilities/Appendix.....53-56

Underwater Solutions for Harsh Environments

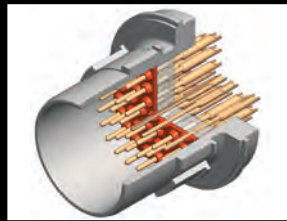

Cooper Interconnect offers one of the most comprehensive product lines of connectors and cable assemblies for Subsea and Underwater environments.

No matter how harsh the environment, Cooper Interconnect provides connectors designed for the toughest conditions, whether requiring a hydrostatic pressure of 20,000 PSI, or ensuring a perfect working camera for an underwater marine picture.

Whatever your underwater interconnection need, Cooper Interconnect has a solution for you.



The Burton name is one of the most trusted in the subsea world, offering high-quality, rugged connectors for the most demanding applications. They are designed for durability and extreme reliability.

Trust your interconnect needs to Cooper Interconnect's Burton connectors.

Solid works models and PDF drawings available upon request.

5500 Series Overview

BURTON

The 5500 Series is an extremely rugged and reliable underwater electrical connector. It is the standard Burton connector series with pins in the receptacles and sockets in the plugs.

The pin and socket relationship is due to the fact that in most applications, power runs from the plug into the receptacle. For safety reasons, it is desirable never to have power available on the pin side. For reverse power applications, refer to Burton's 6600 Series.

For over four decades, the Burton 5500 Series has been the industry standard connector for applications, which require reliable service in severe situations. The rugged metal shells, recessed pins, and face-type seals assure dependable service in the most demanding situations.

Receptacle Installation

Bulkhead connectors should be torqued to the following specifications.

Shell	Torque
15	125 lb-in
16	125 lb-in
20	165 lb-in
24	225 lb-in
32	335 lb-in

For panel mount receptacles, use 4 bolts to hold them in place. Recommended sizes and torques are:

Shell	Bolt	Torque
15	#10	25 lb-in
16	#10	25 lb-in
20	1/4	45 lb-in
24	1/4	45 lb-in
32	5/16	85 lb-in

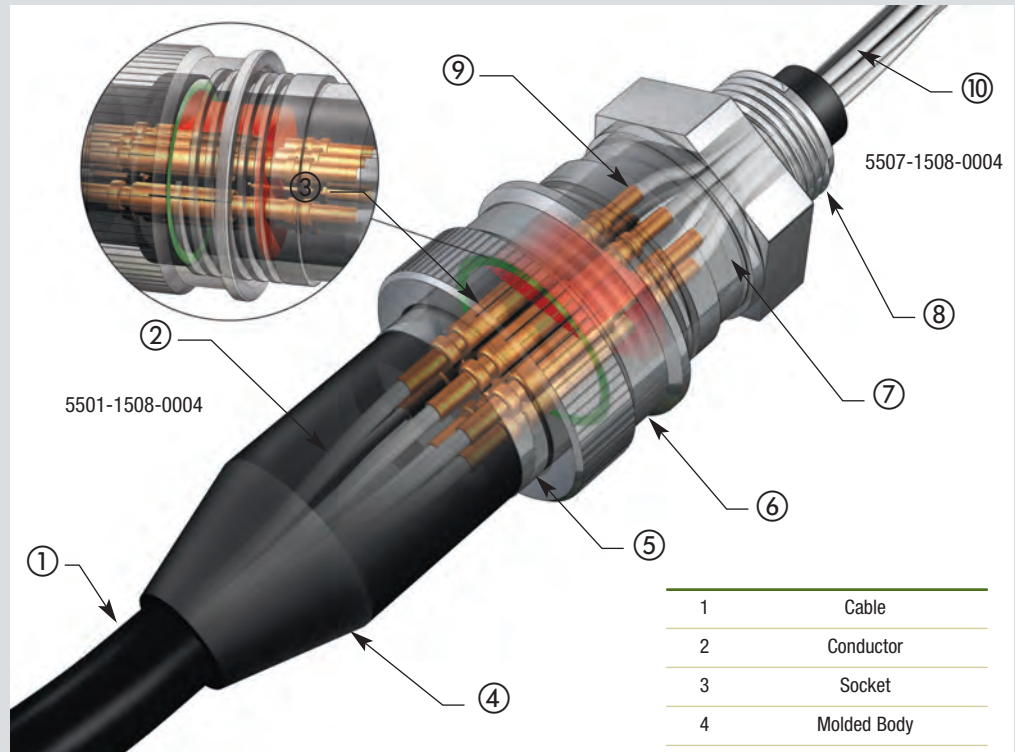

Part Number System

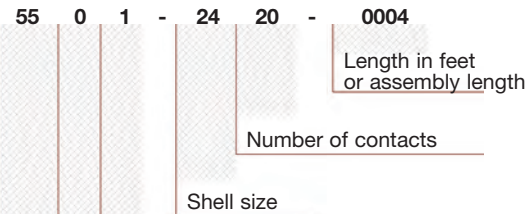

Style:

- 1-CCP
- 2-CCR
- 6-IFCR
- 7-BCR

Special designation:

- A-Attachable
- R-Right angle
- 0-600v (standard)
- 1-1000v
- 2-2000v
- 3-3000v
- 9-1100v (special)

Series

1	Cable
2	Conductor
3	Socket
4	Molded Body
5	Metal Shell
6	Locking Ring
7	Keyway
8	Metal Shell
9	Pin
10	Pigtails

Data and Specifications

Pressure Rating	10,000 PSI
Voltage Rating	600 - 3000
Ampacity	See Appendix

Materials

Contact	High cond. copper alloy
Penetrator Shell	316L SS (passivated) Titanium, Monel, and other materials available upon request
Penetrator Body	Integrally molded elastomer
Cable	UL SOW-A or Mil-C-915
Pigtails	Mil-W-16878

5500 Series Assembly



BURTON

The 5500 Series has a number of features which are designed to make them rugged and reliable even in severe service. Use the Burton 5500 Series for mission critical applications.

5500 Series Features

Burton 5500 Series connectors have no O-Ring seal between the plug and receptacle. Our seal is a face-type seal integrally molded as part of the plug and cannot fall off.

Stub acme threads are used on the 16-size and larger shells. Stub acme threads are difficult to cross thread or damage.

The electrical contacts have crimp connections to the conductor; not solder joints. Crimp contacts have superior flex life compared to soldered joints.

All elastomer to metal bonding surfaces are sandblasted, cleaned, and primed. Then units are molded under several thousand pounds of pressure for 20 or minutes at high temperature. This assures a complete bond which prevents water migration.

Receptacle Features

The Burton 5500 Series receptacles have a unique water blocking system. The water blocking exists down to the conductor level. This means that in the event of a catastrophic failure of the connector system, such as the plug being torn away from the receptacle, water will not enter your valuable equipment. Many competing connector lines do not waterblock down to the conductor level.

The pins are completely contained within the envelope of the metal shell. This means that pins will not be bent or damaged when the connector has been impacted or stepped on.

Plug Features

The plugs have a metal shell under the elastomeric body. It makes them very rugged and resistant to flexing damage.

The plug contacts are completely bonded and isolated from each other. This means that if the cable jacket is damaged and water migrates into the plug, electrical integrity can be maintained.

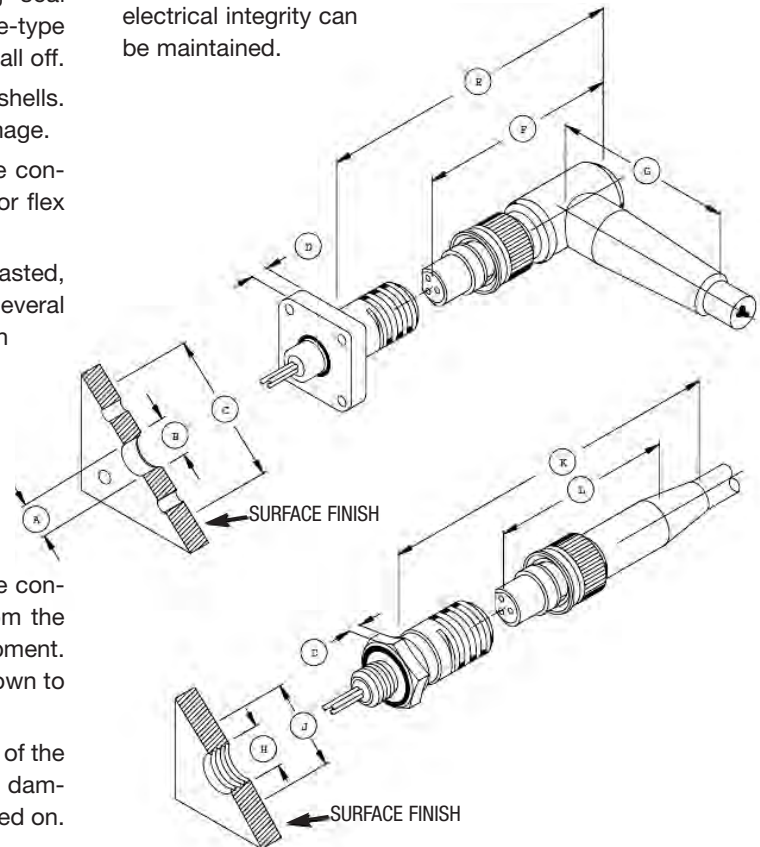

5500 Series Assembly Dimensions in English (Metric)

Shell Size	A	B	C	D	E	F	G	H	J	K	L
15	0.65 (16.5)	0.68 (17.3)	1.95 (49.5)	0.31 (7.9)	3.19 (81.0)	2.75 (69.9)	2.12 (53.8)	0.68 (17.3)	1.30 (33.0)	3.00 (76.2)	1.78 (45.2)
16	0.65 (16.6)	0.68 (17.8)	2.12 (53.8)	0.38 (9.7)	---	---	---	0.68 (17.0)	1.30 (33.0)	3.89 (98.8)	2.45 (62.2)
20	0.77 (19.6)	0.79 (20.1)	2.31 (58.7)	0.38 (9.7)	3.97 (100.8)	3.24 (82.3)	2.90 (73.7)	0.79 (20.1)	1.44 (36.6)	5.40 (137.2)	2.75 (69.9)
24	1.02 (25.9)	1.04 (26.4)	2.66 (67.6)	0.38 (9.7)	4.50 (114.3)	3.87 (98.3)	3.25 (82.6)	1.05 (26.7)	1.73 (43.9)	5.43 (137.9)	2.80 (71.1)
32	1.52 (38.6)	1.54 (39.1)	3.50 (88.9)	0.38 (9.7)	5.13 (130.3)	4.50 (114.3)	4.59 (116.6)	1.55 (39.4)	2.31 (58.7)	6.12 (155.4)	3.94 (100.1)

5500 Series Connector Configurations

Please refer to the illustrations on the facing page. The receptacles (which have pin contacts) are shown on the top. The plugs (which have socket contacts) are shown on the bottom. This is the standard arrangement as power normally flows from the plug into the socket. For safety reasons, the possibility of live power on pins should not be allowed. If the reverse contact arrangement is required, please refer to the Burton 6600 Series.

The descriptions below correspond to the illustration to the right. The part number refers to the first 4 digits of the part number.

BCR Bulkhead Connector Receptacle (5507)

Less expensive than the FCR, this is the standard receptacle mount. It may be used with any plugs. When using the BCR with a right angle plug (CCP-RA), a BCR retaining ring must be used instead of tapped threads. This is due to keyway orientation.

FCR Flange Connector Receptacle (5506)

Like the BCR, this is a mounted receptacle. It is more expensive since it is machined from a larger block of stainless steel. It is also more difficult to mount since it requires five holes instead of one. However, it is ideal for use with the right angle plug since keyway orientation can be controlled. It is possible to get this receptacle with an extra O-Ring seal mounted on the F surface for an additional piston type seal (available by special order).

CCR Cable Connector Receptacle (5502)

An in-line receptacle mounted on a cable. It can be used as part of a cable splice unit or other specialized application.

CCR-AT, Attachable (55A2)

Used in the same applications as the CCR except that it is designed to be attached to its cable by the customer.

CCP Cable Connector Plug (5501)

The standard plug for most applications. Like all of the plugs, it mates to any of the receptacles. This plug is molded to cable at the Cooper Interconnect factory.

CCP-RA Cable connector Plug, Right Angle (55R1)

This plug should be used when the cable must exit the receptacle at a 90-degree angle. Normally, the FCR is recommended for use with the right angle plug to assure keyway orientation.

CCP-AT Cable Connector Plug, Attachable (55A1)

Used in the same applications as the CCP except that it is designed to be attached to its cable by the customer. A variation of this plug is available as a PBOF (pressure balanced oil filled) assembly. The connector shell is modified to accept a new backshell, which has an oil fill port and a hose attachment. Please see page 11 for details.

5500 Series Dimensions in English (Metric)

Shell Size	5A thd*	5B	5C	5D	5E	5F	5G	5H thd*	5J	5K	5L	5M dia	5N	5P dia	5R	O-Ring	5S	5T dia	5U	5X
15	15/16-20	2.45 (62.2)	1.09 (27.7)	1.13 (28.6)	1.25 (31.8)	0.50 (12.7)	0.31 (7.92)	5/8-18	1.00 (25.4)	1.50 (38.10)	2.12 (53.8)	0.63 (15.88)	1.47 (37.3)	0.78 (19.8)	1.55 (39.4)	-116	0.68 (17.35)	0.22 (5.563)	2.75 (69.9)	2.87 (72.9)
16	1-9	3.31 (84.1)	1.17 (29.7)	1.13 (28.6)	1.50 (38.1)	0.50 (12.7)	0.38 (9.53)	5/8-18	1.13 (28.6)	1.63 (41.28)	—	0.63 (15.88)	—	—	—	-116	—	0.22 (5.563)	—	—
20	1-1/4-9	4.80 (121.9)	1.50 (38.1)	1.25 (31.8)	1.50 (38.1)	0.50 (12.7)	0.38 (9.53)	3/4-16	1.25 (31.8)	1.75 (44.45)	2.90 (73.7)	0.74 (18.80)	1.59 (40.4)	1.06 (26.9)	1.66 (42.2)	-118	1.087 (27.61)	0.28 (7.137)	3.24 (82.3)	4.10 (104.1)
24	1-1/2-9	4.80 (121.9)	1.75 (44.5)	1.50 (38.1)	1.50 (38.1)	0.50 (12.7)	0.38 (9.53)	1-14	1.50 (38.1)	2.00 (50.80)	3.25 (82.6)	0.99 (25.15)	1.68 (42.7)	1.32 (33.5)	1.66 (42.2)	-122	1.32 (33.63)	0.28 (7.137)	3.87 (98.3)	4.88 (124.0)
32	2-9	5.57 (141.5)	2.25 (57.2)	2.00 (50.8)	1.50 (38.1)	0.50 (12.7)	0.38 (9.53)	2-9	2.00 (50.8)	2.63 (66.68)	4.59 (116.6)	1.49 (37.85)	1.70 (43.2)	1.81 (46.0)	1.78 (45.2)	-130	1.81 (46.02)	0.34 (8.738)	4.50 (114.3)	5.57 (141.6)

5500 Series Connector Configurations



BURTON

<p>BCR RECEPTACLE, BULKHEAD PIN INSERT 5507 SERIES</p>		
<p>FCR RECEPTACLE, FLANGE PIN INSERT 5506 SERIES</p>		
<p>CCR RECEPTACLE, CABLE PIN INSERT 5502 SERIES</p>		
<p>CCR-AT RECEPTACLE, ATTACHABLE 55A2 SERIES</p>		
<p>CCP PLUG, CABLE SOCKET INSERT 5501 SERIES</p>		
<p>CCP-RA PLUG, RIGHT ANGLE SOCKET INSERT 55R1 SERIES</p>		
<p>CCP-AT PLUG, ATTACHABLE 55A1 SERIES</p>		

5500 Series Contact Arrangements

Face view of pin connectors shown. Attaching wire sizes are in parentheses.

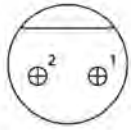

1502
(2 #16 AWG)

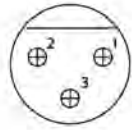

1503
(3 #16 AWG)

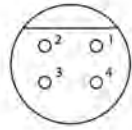

1504
(4 #18 AWG)

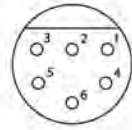

1506
(6 #18 AWG)

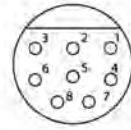

1508
(8 #18 AWG)

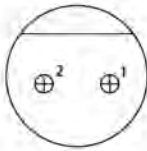

1602
(2 #16 AWG)

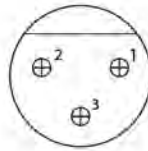

1603
(3 #16 AWG)

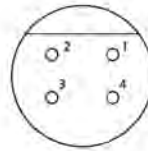

1604
(4 #18 AWG)

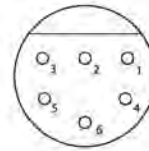

1606
(6 #18 AWG)

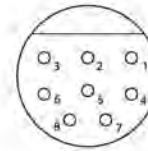

1608
(8 #18 AWG)

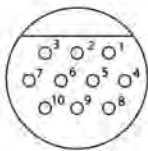

1610
(10 #18 AWG)

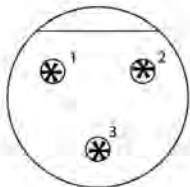

2003
(3 #16 AWG)

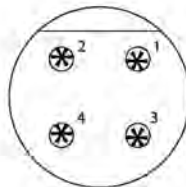

2004
(4 #16 AWG)

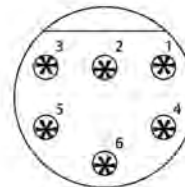

2006
(6 #16 AWG)

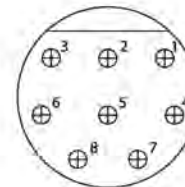

2008
(8 #16 AWG)

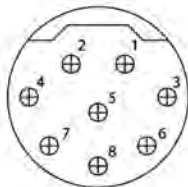

20A8
(8 #16 AWG)

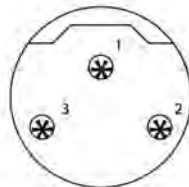

20B3
(3 #16 AWG)

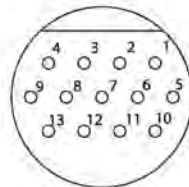

2013
(13 #18 AWG)

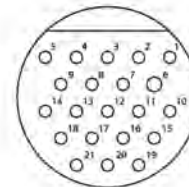

2021
(21 #18 AWG)

5500 Series Contact Arrangements

Face view of pin connectors shown. Attaching wire sizes are in parentheses.

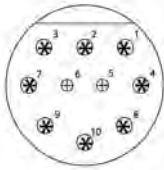

2410
(10 #16 AWG)

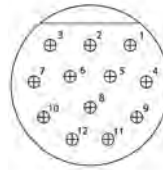

2412
(12 #16 AWG)

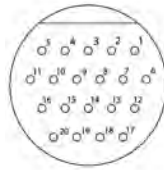

2420
(20 #18 AWG)

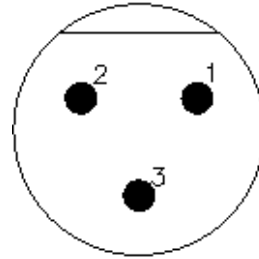

3203
(3 #8 AWG)

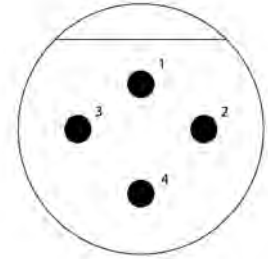

3204
(4 #8 AWG)

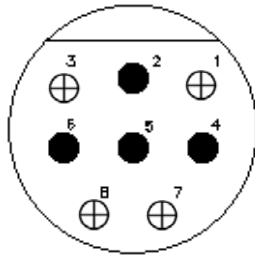

3208
(4 #16 AWG)
(4 #8 AWG)

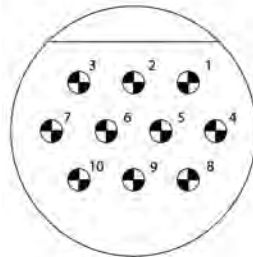

3210
(10 #16 AWG)

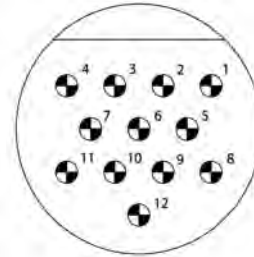

3212
(12 #16 AWG)

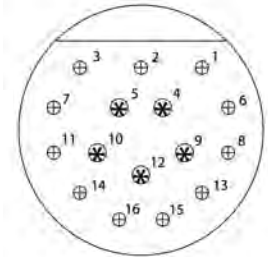

3216
(16 #16 AWG)

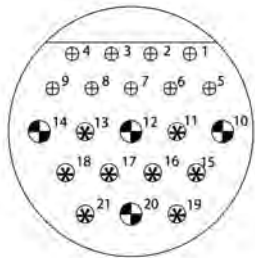

3221
(21 #16 AWG)

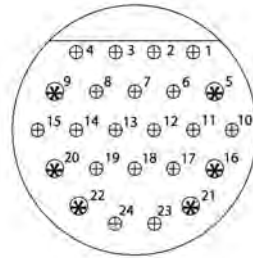

3224
(24 #16 AWG)

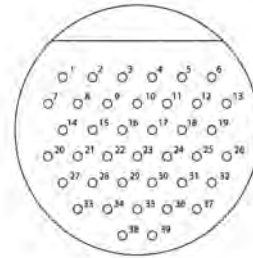

3239
(39 #18 AWG)

PIN DIAMETER	1/16	3/32	1/8	5/32	3/16
	○	⊕	⊗	⊙	●

The contact patterns shown on these 2 pages are available for any connector type with the Cooper Interconnect 5500 Series. Cooper Interconnect is constantly adding new items. Some contact patterns are available with larger sized

conductors. For example, the 3210 and 3212 are available with up to 12 AWG conductors. For high voltage contact patterns, please see the next page.

5500 Series High Voltage Connectors

BURTON

5500 Series High Voltage Connectors

A number of 5500 Series contact patterns are available with higher voltage ratings (standard rating is 600v). Ratings of 1000v, 2000v, and 3000v are available. Due to certain design constraints and material limitations, not all patterns are available in all voltage ratings.

The Burton 5500 Series high voltage connectors differ from the standard rated units in several areas. There is a contact shoulder, which increases the surface track distance between contacts. Different insulation materials may also be used.

All Cooper Interconnect high voltage connectors differ from the standard rated units in several areas. There is a contact shoulder, which increases the surface track distance between contacts. Different insulation materials may also be used.

All Cooper Interconnect high voltage connectors are built to be equally rugged and reliable as the standard voltage rated items.

The following contact patterns are available. Cooper Interconnect is continuously adding products; please contact the factory for availability of other patterns or specific requirements.

High Voltage Availability			
Pattern	1000v	2000v	3000v
1502	X	X	
1503	X	X	
2004	X	X	X
2006	X		
2013	X		
2403	X	X	X
2410	X	X	
2420	X		
3203	X	X	X
3204	X	X	X
3210	X	X	X
3212	X	X	
3215	X	X	X
3224	X		
3239	X		

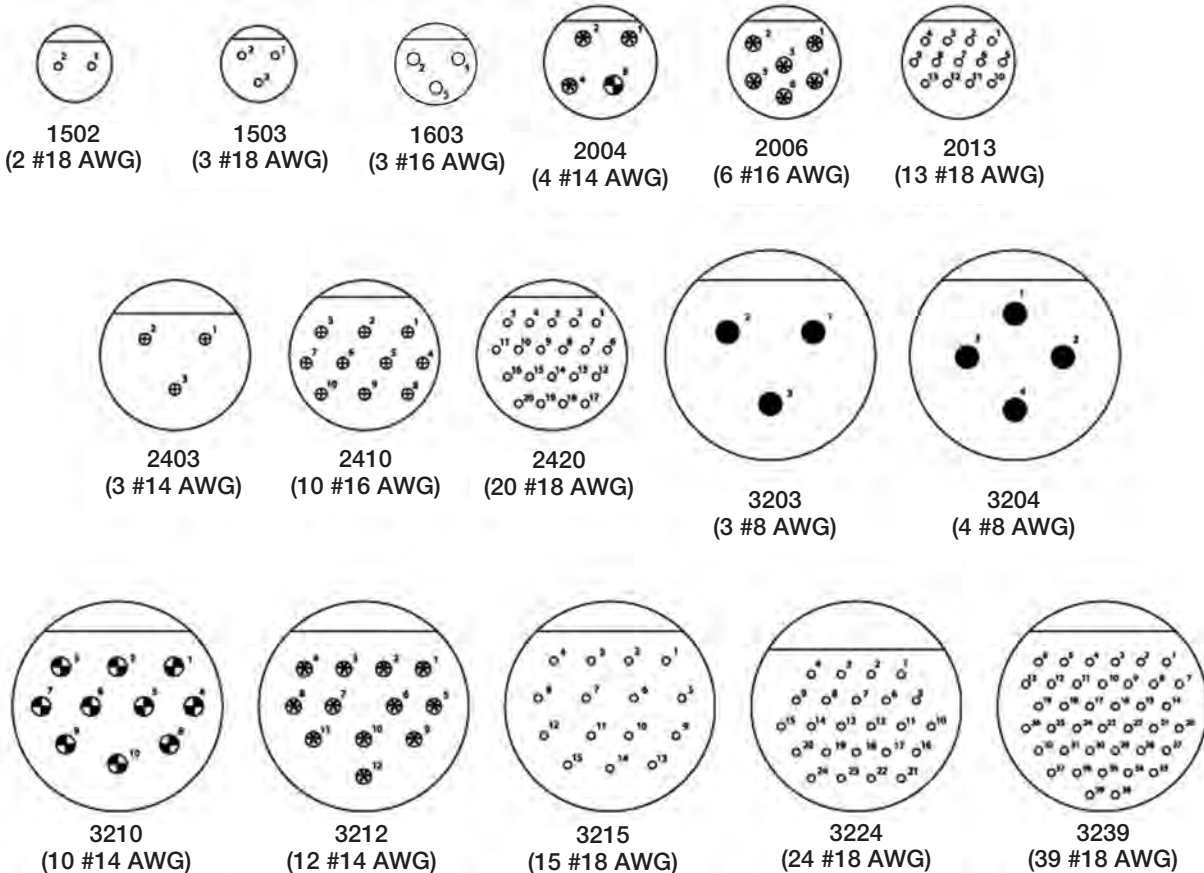

Face view of pin connectors shown. Attaching wire sizes are in parentheses.

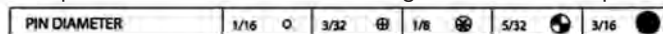

5500 Series PBOF Plugs

Pressure Balanced Oil Filled (PBOF)

The 5500 plugs are also available in PBOF form factor. The plug is a modified 55A1 attachable designed to accommodate a special backshell which has a hose barb and oil fill port. The part number becomes 55P1-XXXX-0000.



Shell Size	A	B	C	D
9	2.29	1.72	0.66	0.40
15	3.80	2.75	1.12	0.67
16	3.95	2.80	1.25	0.67
20	4.04	2.94	1.50	0.67
24	4.19	3.22	1.75	0.67
32	4.25	3.22	2.22	1.00

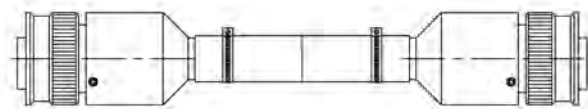
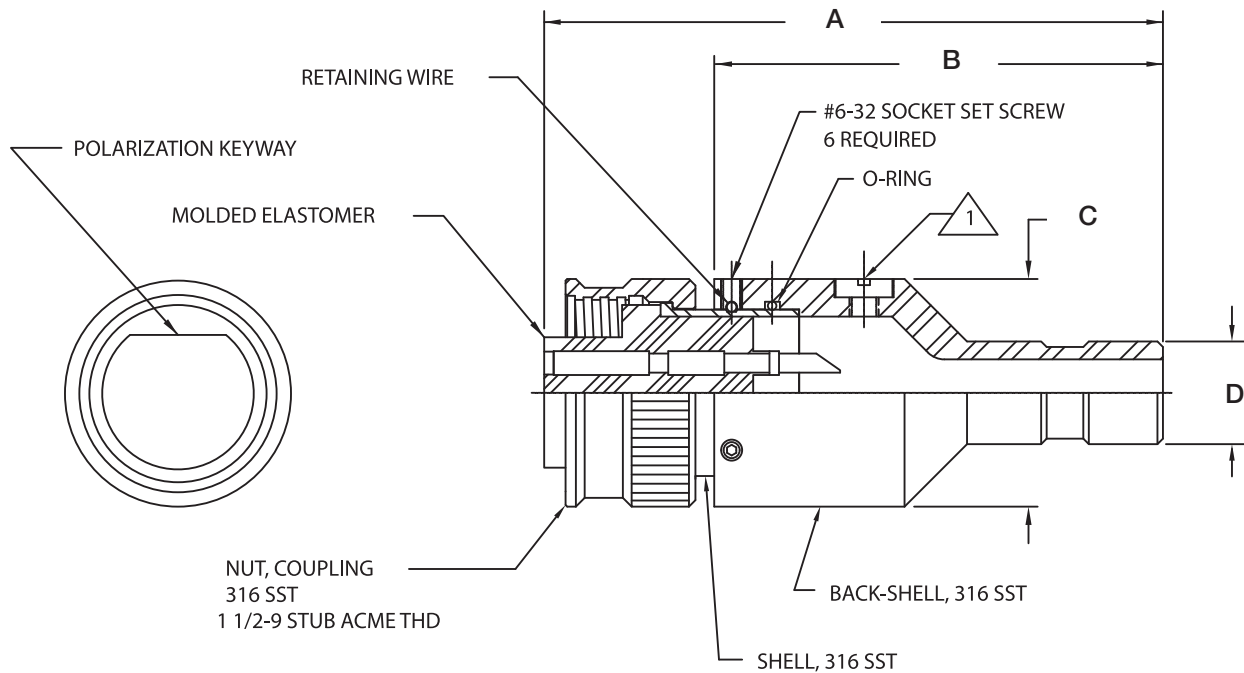

For special extreme applications, a JIC type fitting is available on the backshell. This makes it possible to use a hydraulic hose instead of clear tubing.

PBOF connectors may be ordered separately or made up as cable assemblies. Due to the difficulty of shipping cable assemblies with oil, we leave that to the customer.

5500 Series Accessories

BURTON

A number of accessories are available for the 5500 Series. Some are shown on this page. Please contact the factory for specific requests.

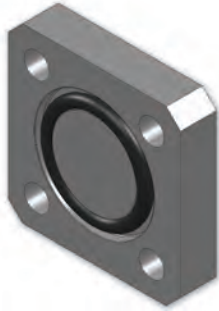

FCR Mounting Cover	
Size	Part Number
15	5106-1500-0000
16	5106-1600-0000
20	5106-2000-0000
24	5106-2400-0000
32	5106-3200-0000

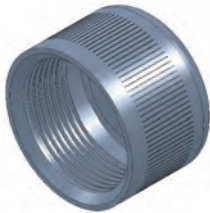

Receptacle Pressure Cap (SS)	
Size	Part Number
15	5101-1500-0000
16	5101-1600-0000
20	5101-2000-0000
24	5101-2400-0000
32	5101-3200-0000

Pressure caps rated to 500psi



Dummy Plug	
Size	Part Number
15	5501-15XX-0000
16	5501-16XX-0000
20	5501-20XX-0000
24	5501-24XX-0000
32	5501-32XX-0000

Dummy Plugs need to be used when full working pressure is required. Dummy Plugs are available for all sizes of cables and receptacles. Size the dummy plug as you would the mating connector.



Receptacle Dust Cap (hard rubber)	
Size	Part Number
15	6700-0124-0151
16	6700-0124-0161
20	6700-0124-0201
24	6700-0124-0241
32	6700-0124-0321

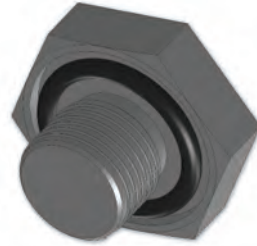

BCR Mounting Plug	
Size	Part Number
15	5107-1500-0000
16	5107-1600-0000
20	5107-2000-0000
24	5107-2400-0000
32	5107-3200-0000

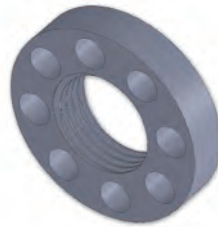

BCR Retaining Ring	
Size	Part Number
15	5109-1500-0000
16	5109-1600-0000
20	5109-2000-0000
24	5109-2400-0000
32	5109-3200-0000



Plug Dust Cap (hard rubber)	
Size	Part Number
15	6700-0125-0151
16	6700-0125-0161
20	6700-0125-0201
24	6700-0125-0241
32	6700-0125-0321

5500 Series Custom Solutions

COOPER Interconnect



Shell Size 9



Plug Size 48



Receptacle Size 48

BURTON

Cooper Interconnect has expanded in both directions on our line of 5500 series Rubber Molded Metal Shell connectors. Our “Mini” shell size 9 connector is only 1/2” in diameter. Ideal for small instrumentation, cameras, or any application where space is an issue. We also expanded our line for very large “high-current” shell size 48 connectors and beyond. This connector can accommodate high current requirements for underwater motors, pumps and windfarms at sea.

6600 Series Assembly

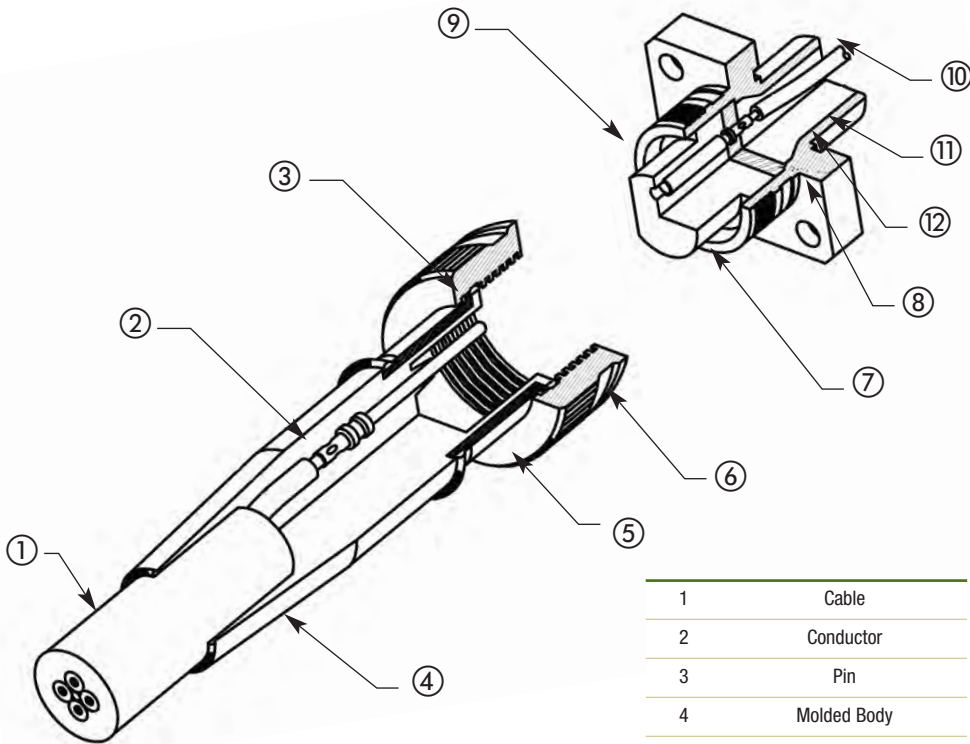

Part Number System

66 0 1 - 24 20 - 0004

Length in feet

Number of contacts

Shell size

Style:

- 1-CCP
- 2-CCR
- 6-FCR
- 7-BCR

Special designation:

- A-Attachable
- R-Right angle
- 0-600v (standard)
- 1-1000v
- 2-2000v
- 3-3000v
- 9-1100v (special)

Series

1	Cable
2	Conductor
3	Pin
4	Molded Body
5	Metal Shell
6	Locking Ring
7	Recept. Face
8	Metal Shell
9	Socket
10	Pigtails
11	Epoxy Backfill

Data and Specifications

Pressure Rating	10,000 PSI
Voltage Rating	600 – 3000
Ampacity	See Appendix

Materials

Contacts	High cond. copper alloy
Penetrator Shell	316L SS (passivated)
Penetrator Body	Integrally molded elastomer
Cable	UL SOW-A or Mil-C-915
Pigtails	Mil-W-16878

The 6600 Series is an extremely rugged and reliable underwater electrical connector. It is the alternate Burton connector series with pin in the plugs and sockets in the receptacles (the inverse of the 5500 series).

Occasionally, it is desirable to run power from the receptacle to the plug (for example a power supply or battery pack). In these instances, use the 6600 Series. For safety reasons, it is desirable to never have power available on the pin side. For reverse (standard) power applications, refer to Burton's 5500 Series. Along with the Burton 5500 Series, the 6600 Series has for over two decades become the industry standard connector for applications, which require reliable service in severe situations. The rugged metal shells, recessed pins, and face type seals assure dependable service in the most demanding situations.

6600 Series Overview



BURTON

Like the 5500 Series, the 6600 Series has a number of features which are designed to make them rugged and reliable even in severe service. Use the Burton 6600 Series for mission critical applications where you need power flowing in opposite the usual direction.

6600 Series Features

Burton 6600 Series connectors have no O-Ring seal between the plug and receptacle. That seal is a face type seal integrally molded as part of the plug and cannot fall off.

Stub acme threads are used on all shell sizes. Stub acme threads are difficult to cross thread or damage.

The electrical contacts have crimp connections to the conductor; not solder joints. Crimp contacts have superior flex life compared to soldered joints.

All elastomer to metal bonding surfaces are sandblasted, cleaned and primed. Then units are molded under several thousand pounds of pressure for 20 or more minutes at 300+ degrees. This assures a complete bond which prevents water migration.

Receptacle Features

Like the Cooper Interconnect 5500 Series, the 6600 Series receptacles have a unique water blocking system. The water blocking exists down to the conductor level. This means that in the event of a catastrophic failure of the connector system such as the plug being torn away from the receptacle – water will not enter your valuable equipment. Many competing connector lines do not water block down to the conductor level.

Plug Features

The plugs have a metal shell under the elastomeric body. It makes them very rugged and resistant to flexing damage.

The pins are completely contained within the envelope of the metal shell. This means that the pins will not be bent or damaged when the connector has been impacted or stepped on. The plug contacts are completely bonded and isolated from each other. This means that if the cable jacket is damaged and water migrates into the plug, electrical integrity can be maintained.

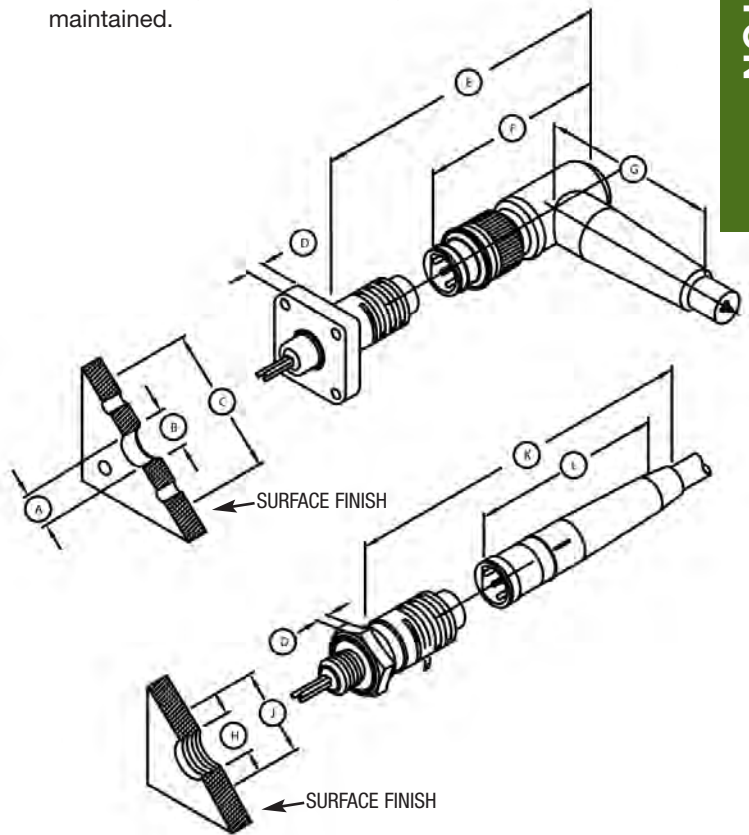

6600 Series Assembly Dimensions in English (Metric)

Shell Size	A	B	C	D	E	F	G	H	J	K	L
16	0.64 (16.3)	0.66 (16.8)	2.12 (54.6)	0.375 (9.5)	---	---	---	0.79 (20.1)	1.44 (36.6)	3.72 (94.5)	2.15 (54.6)
20	0.77 (19.6)	0.79 (20.1)	2.28 (57.9)	0.375 (9.5)	4.00 (101.6)	3.24 (82.3)	2.90 (73.7)	0.79 (20.1)	1.44 (36.6)	5.26 (133.6)	2.14 (54.4)
24	1.02 (25.9)	1.04 (26.4)	2.63 (66.8)	0.375 (9.5)	4.50 (114.3)	3.87 (98.3)	3.25 (82.6)	1.05 (26.7)	1.73 (43.9)	5.87 (149.1)	2.30 (59.2)
32	1.52 (38.6)	1.54 (39.1)	3.50 (88.9)	0.375 (9.5)	5.13 (130.3)	4.50 (114.3)	4.59 (116.6)	1.55 (39.4)	2.31 (58.7)	6.57 (166.9)	3.50 (88.9)

6600 Series Configurations

Please refer to the illustration on the facing page. The receptacles (which have socket contacts) are shown on the top. The plugs (which have pin contacts) are shown on the bottom. This pin/socket relationship is opposite of the 5500 Series. It is used for occasions where you wish power to flow from the receptacle to the plug. For safety reasons, the possibility of live power on pins should not be allowed. If the reverse contact arrangement is required, please refer to the Burton 5500 Series.

The descriptions below correspond to the illustration to the right. The part numbers refers to the first 4 digits of the part number.

BCR Bulkhead Connector Receptacle (6607)

Less expensive than the FCR, this is the standard receptacle mount. It may be used with any plugs. When using the BCR with a right angle plug (CCP-RA), a BCR retaining ring must be used instead of tapped threads. This is due to keyway orientation.

FCR Flange Connector Receptacle (6606)

Like the BCR, this is a mounted receptacle. It is more expensive since it is machined from a larger block of stainless steel. It is also more difficult to mount since it requires 5 holes instead of 1. However, it is ideal for use with the right angle plug since keyway orientation can be controlled. It is possible to get this receptacle with an extra O-Ring seal mounted on the F surface for an additional piston type seal (available by special order).

CCR Cable Connector Receptacle (6602)

An in-line receptacle mounted on a cable. It can be used as part of a cable splice unit or other specialized application.

CCR-AT, Attachable (66A2)

Used in the same applications as the CCR except that it is designed to be attached to its cable by the customer.

CCP Cable Connector Plug (6601)

The standard plug for most applications. Like all of the plugs, it mates to any of the receptacles. This plug is molded to cable at the Cooper Interconnect factory.

CCP-RA Cable Connector Plug, Right Angle (66R1)

This plug should be used when the cable must exit the receptacle at a 90-degree angle. Normally, the FCR is recommended for use with the right angle plug to assure keyway orientation.

CCP-AT Cable Connector Plug, Attachable (66A1)

Used in the same applications as the CCP except that it is designed to be attached to its cable by the customer. A variation of this plug is available as a PBOF (pressure balanced oil filled) assembly. The connector shell is modified to accept a new backshell, which has an oil fill port and a hose attachment. Please consult the factory for details.

6600 Series Dimensions in English (Metric)

Shell Size	6A thd*	6B	6C	6D	6E	6F	6G	6H thd*	6J	6K	6L	6M dia	6N	6P dia	6R	O-Ring	6S	6T dia	6U	6X
16	1-9	3.01 (76.5)	1.17 (29.7)	1.13 (28.6)	1.50 (38.1)	0.50 (12.7)	0.375 (9.53)	5/8-18	1.125 (28.6)	1.625 (41.28)	—	0.615 (15.62)	—	—	1.72 (43.7)	-116	0.837 (21.26)	0.219 (5.563)	—	—
20	1-1/4-9	3.74 (95.0)	1.50 (38.1)	1.25 (31.8)	1.50 (38.1)	0.50 (12.7)	0.375 (9.53)	3/4-16	1.25 (31.8)	1.75 (44.45)	2.90 (73.7)	0.74 (18.80)	1.59 (40.4)	1.06 (26.9)	1.62 (41.1)	-118	1.087 (27.61)	0.281 (7.137)	3.24 (82.3)	4.12 (104.7)
24	1-1/2-9	4.33 (110.0)	1.75 (44.5)	1.50 (38.1)	1.50 (38.1)	0.50 (12.7)	0.375 (9.53)	1-14	1.50 (38.1)	2.00 (50.80)	3.57 (73.7)	0.99 (25.15)	1.68 (42.7)	1.32 (33.5)	1.62 (41.1)	-122	1.32 (33.63)	0.281 (7.137)	3.87 (98.3)	4.78 (121.4)
32	2-9	5.07 (128.8)	2.25 (57.2)	2.00 (50.8)	1.50 (38.1)	0.50 (12.7)	0.375 (9.53)	2-9	2.00 (50.8)	2.63 (66.68)	4.59 (116.6)	1.49 (37.85)	1.70 (43.2)	1.81 (46.0)	1.62 (41.1)	-130	1.81 (46.02)	0.344 (8.738)	4.50 (114.3)	5.47 (138.9)

6600 Series Configurations

<p>BCR RECEPTACLE, BULKHEAD SOCKET INSERT 6607 SERIES</p>		
<p>FCR RECEPTACLE, FLANGE SOCKET INSERT 6606 SERIES</p>		
<p>CCR RECEPTACLE, CABLE SOCKET INSERT 6602 SERIES</p>		
<p>CCR-AT RECEPTACLE, ATTACHABLE 66A2 SERIES</p>		
<p>CCP PLUG, CABLE PIN INSERT 6601 SERIES</p>		
<p>CCP-RA PLUG, RIGHT ANGLE PIN INSERT 66R1 SERIES</p>		
<p>CCP-AT PLUG, ATTACHABLE 66A1 SERIES</p>		

6600 Series Contact Arrangements

Face view of pin connectors shown. Attaching wire sizes are in parentheses.

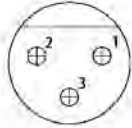

1603
(3 #16 AWG)



1608
(8 #18 AWG)

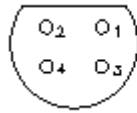

1604
(4 #18 AWG)



1606
(6 #18 AWG)

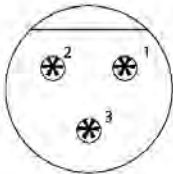

2003
(3 #16 AWG)

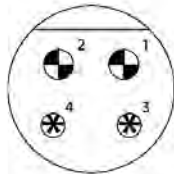

2004
(4 #16 AWG)

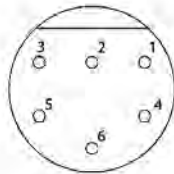

2006
(6 #18 AWG)

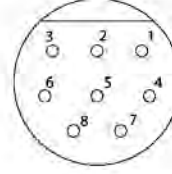

2008
(8 #18 AWG)

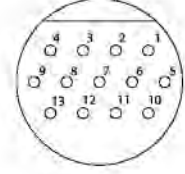

2013
(13 #18 AWG)

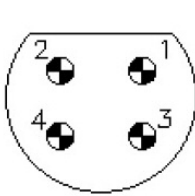

2404
(4 #12 AWG)

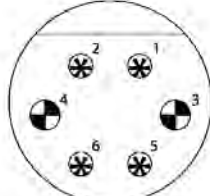

2406
(6 #16 AWG)

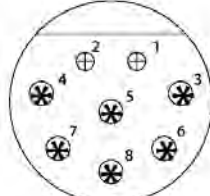

2408
(8 #16 AWG)

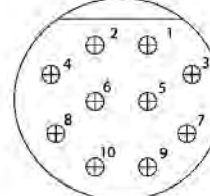

2410
(10 #16 AWG)

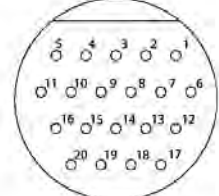

2420
(20 #18 AWG)

6600 Series Contact Arrangements



BURTON

Face view of pin connectors shown. Attaching wire sizes are in parentheses.

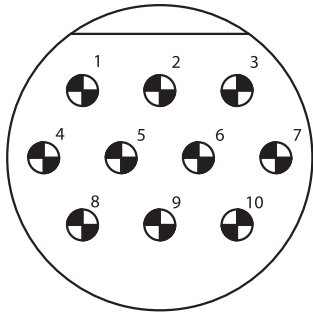

3210
(10 #16 AWG)

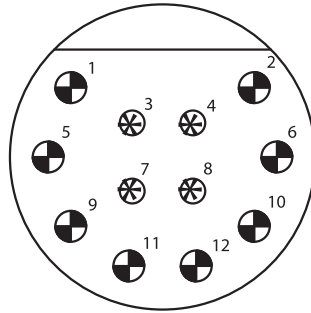

3212
(12 #16 AWG)

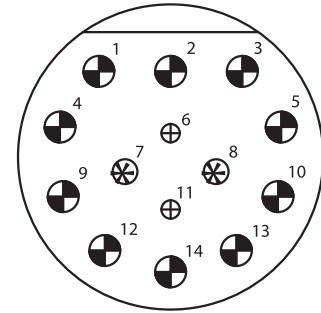

3214
(14 #16 AWG)

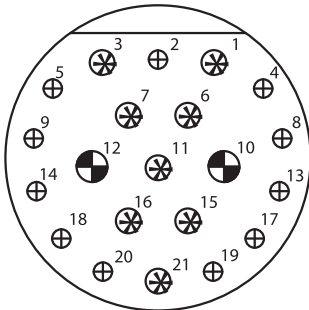

3221
(21 #16 AWG)

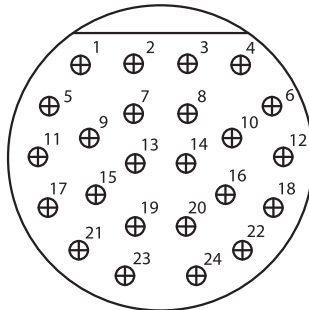

3224
(24 #16 AWG)

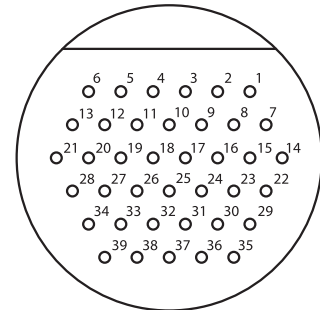

3239
(39 #18 AWG)

PIN DIAMETER	1/16 ○	3/32 ⊕	1/8 ⊗	5/32 ⊕	3/16 ●
--------------	--------	--------	-------	--------	--------

The contact patterns shown on these two pages are available for any connector type with the Cooper Interconnect 6600 Series. All Cooper Interconnect 6600 Series connectors are available in high voltage ratings. Please contact the factory for details.

6600 Series High Voltage Connectors

6600 Series High Voltage Connectors

A number of 6600 Series contact patterns are available with higher voltage ratings (standard rating is 600v). Ratings of 1000v, 2000v, and 3000v are available. Due to certain design constraints and material limitations, not all patterns are available in all voltage ratings.

The Burton 6600 Series high voltage connectors differ from the standard rated units in several areas. There is a contact shoulder, which increases the surface track distance between contacts. Different insulation materials may also be used.

All Burton high voltage connectors are built to be equally rugged and reliable as the standard voltage rated items.

The following contact patterns are available. Cooper Interconnect is continuously adding products; please contact the factory for availability of other patterns or specific requirements.

Pattern	High Voltage Availability		
	1000v	2000v	3000v
1603	X	X	
2004	X	X	X
2013	X		
2403	X	X	X
3203	X	X	X
3204	X	X	X
3239	X		

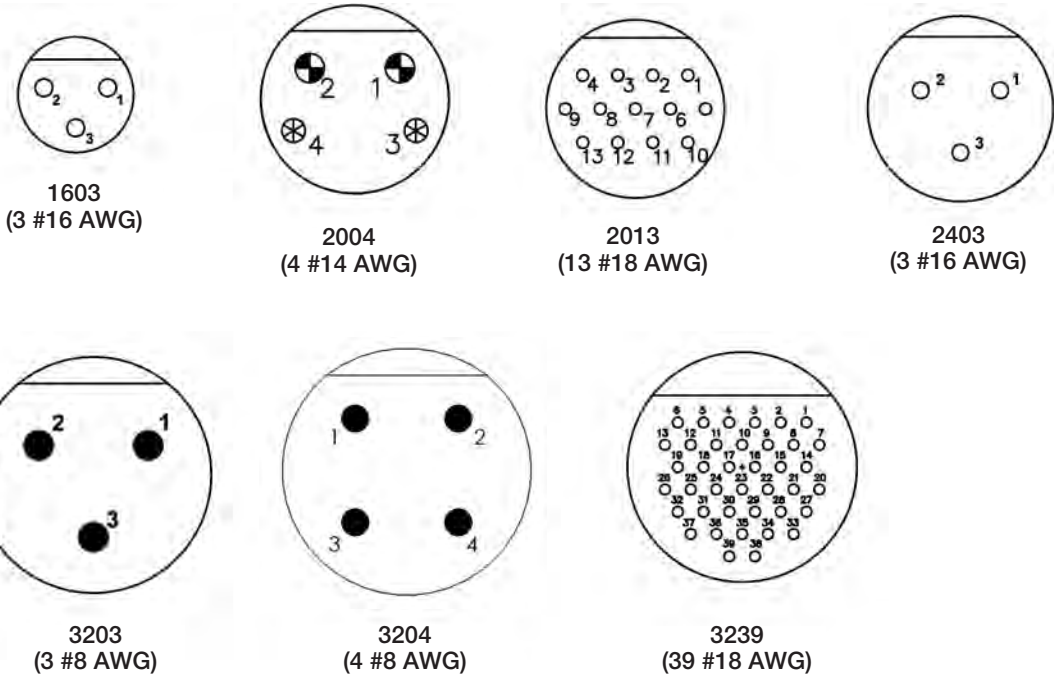

Face view of pin connectors shown. Attaching wire sizes are in parentheses.

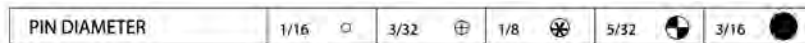

6600 Series Accessories



BURTON

A number of accessories are available for the 6600 Series. Some are shown on this page. Please contact the factory for specific requests.

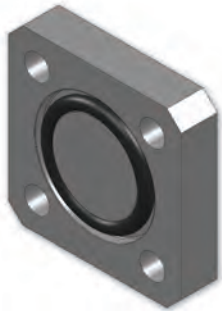

FCR Mounting Cover	
Size	Part Number
16	5106-1600-0000
20	5106-2000-0000
24	5106-2400-0000
32	5106-3200-0000

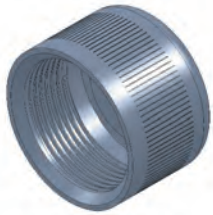

Receptacle Pressure Cap (SS)	
Size	Part Number
16	6101-1600-0000
20	6101-2000-0000
24	6101-2400-0000
32	6101-3200-0000

Pressure caps rated to 500psi



Dummy Plug	
Size	Part Number
16	6601-16XX-0000
20	6601-20XX-0000
24	6601-24XX-0000
32	6601-32XX-0000

Dummy Plugs need to be used when full working pressure is required. Dummy Plugs are available for all sizes of cables and receptacles. Size the dummy plug as you would the mating connector.



Receptacle Dust Cap (hard rubber)	
Size	Part Number
16	6700-0520-0161
20	6700-0520-0201
24	6700-0520-0241
32	6700-0520-0321

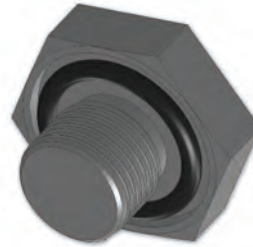

BCR Mounting Plug	
Size	Part Number
16	5107-1600-0000
20	5107-2000-0000
24	5107-2400-0000
32	5107-3200-0000

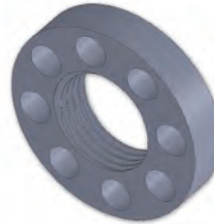

BCR Retaining Ring	
Size	Part Number
16	5109-1600-0000
20	5109-2000-0000
24	5109-2400-0000
32	5109-3200-0000



Plug Dust Cap	
Size	Part Number
16	6700-0125-0161
20	6700-0125-0201
24	6700-0125-0241
32	6700-0125-0321

5400 Series

BURTON

The 5400 Series is an extremely rugged and reliable underwater electrical penetrator for pressures of up to 10,000 psi. It should be used in situations where electrical disconnection is unneeded or unwanted.

A complete Cooper Interconnect-style conductor level water blocking system protects valuable pressure bottles in the event of a catastrophic failure such as the destruction of the penetrator face or the cable being torn away.

Only available in the straight configuration. For applications requiring right angle, please consult the factory. Special configurations are available such as high voltage, pipe threaded bulkhead mount, and flange mount

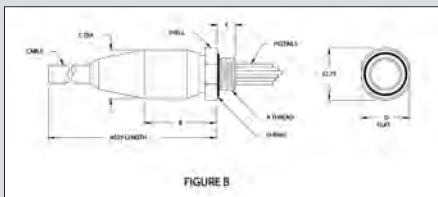
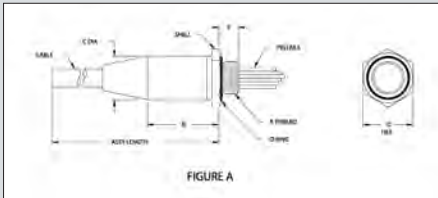

1	Cable
2	Conductor
3	"blind" contact
4	Molded body
5	Pressure wafer
6	Epoxy backfill
7	Pigtails

Data and Specifications	
Pressure Rating	10,000 PSI
Voltage Rating	600 - 3000
Ampacity	see Appendix

Materials	
Contacts	High cond. copper alloy
Penetrator Shell	316L SS (passivated)
Penetrator Body	Integrally molded elastomer
Cable	UL SOW-A or Mil-C-915
Pigtails	Mil-W-16878

Part Number System
54 0 0 - 16 08 - 0004

Length in feet
 Number of contacts
 Shell size
 Style:
 0-straight (bulkhead mount)
 6-flange mount
 Special designation:
 0-600v (standard)
 1-1000v
 2-2000v
 3-3000v
 Series

Part #	Figure	A	B	C	D	E	Size	O-Ring
1001		5/8	1.75	1.10	1.125	0.50	8 AWG	
1002	A	18NF	(44.5)	(27.9)	(28.7)	(12.7)	12 AWG	2-116
1004							16 AWG	
1601							4 AWG	
1604	A	1	2.00	1.45	1.50	0.50	8 AWG	2-122
1608		14NF	(50.8)	(36.8)	(38.1)	(12.7)	14 AWG	
1620							16 AWG	
2401							1/0	
2404	A	1-1/2	3.60	1.85	2.00	0.50	4 AWG	2-130
2410		12NF	(91.4)	(47.0)	(50.8)	(12.7)	12 AWG	
2424							16 AWG	
2804							2 AWG	
2820	B	1-3/4	6.50	2.75	2.50	1.25	12 AWG	2-134
2832		12NF	(165.1)	(69.9)	(63.5)	(31.8)	16 AWG	

Single Pin Penetrators

Cooper Interconnect offers a number of models of single pin penetrators and inline connectors. These penetrators are typically used where space is at a premium and/or extremely high pressures are expected.

The penetrators include a glass sealed contact and so most designs can also withstand equal back pressure (internal pressure), partially depending on their O-Ring configuration.

Burton Single Pin Dimensions

Penetrator	pin OD	thread	hex
5002-1501-0000	0.062	1/4-28 UNF	0.375
5012-1501-0000	0.093	5/16-24 UNF	0.437

Connector, pin	A	B	C
5002-0011-XXXX	0.062	0.44	1.00
5012-0011-XXXX	0.093	0.44	1.06

Connector, socket	D	E	F
5002-0012-XXXX	0.312	0.312	1.32
5012-0012-XXXX	0.375	0.375	1.43

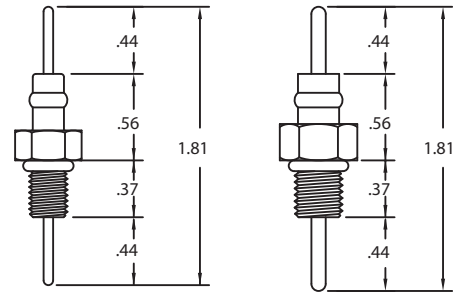
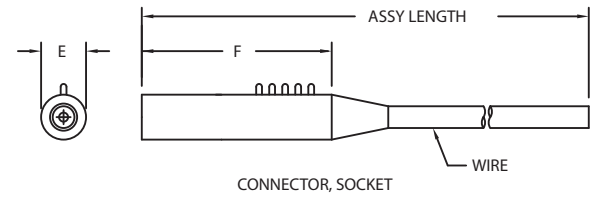
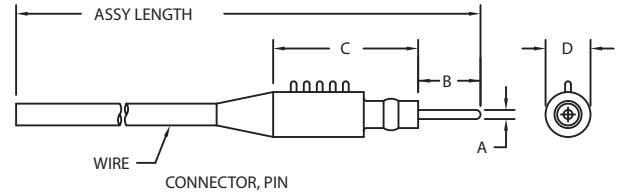

Back Pressure (Motor) Penetrator

Some penetrator applications are subject to back pressure. An example is a submerged motor. Normally pressure balanced, an overheated motor may have higher pressure inside. Most penetrators are not capable of handling this condition resulting in oil or water entering the penetrator from the rear causing it to fail electrically. Burton has developed a line of penetrators that can handle this back pressure. Capacities include voltages from 600v to 5kV; and ampacities over 140. Please contact the factory with your specific requirements. The example above is a 5kV, 6AWG (36 amp) motor penetrator.

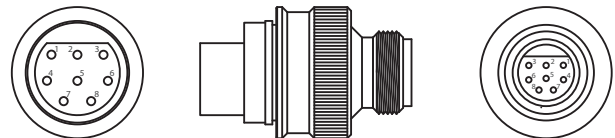
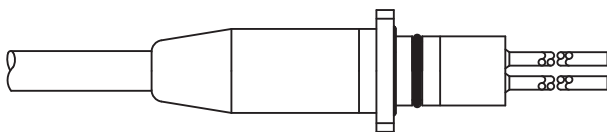

Ethernet and Power Cable Assemblies

BURTON



Cooper Interconnect's Burton Underwater Ethernet Cable Assemblies provide power and data connections in the harshest environments.

Just one cable assembly provides both high speed (up to 1GB/SEC) Internet connection and power (600 Volts) in a subsea environment.

Our ethernet and cable assemblies are of the highest quality to withstand harsh undersea environments. We use only tested Burton 5500/6600 connectors with custom-designed cables to provide both data and power communication in the one assembly.

PERFORMANCE & FEATURES:

- 1000BaseT network performance with power.
- Connectors and cables rated to 10,000 psi.
- TIA/EIA-568-B.2.
- IEEE 802.3-2005
- Pure Ethernet available in shell sizes 15.

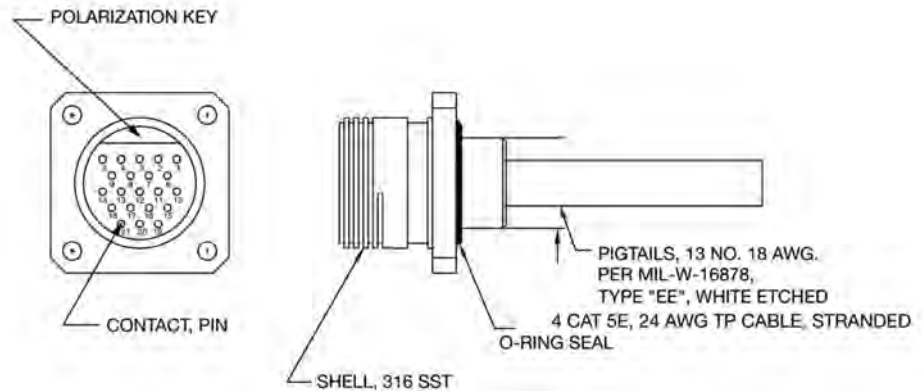
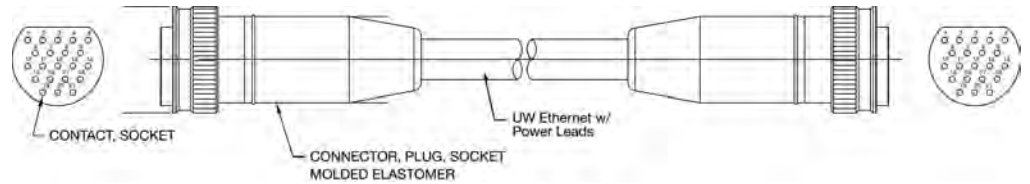

Ethernet and Power Cable Assemblies

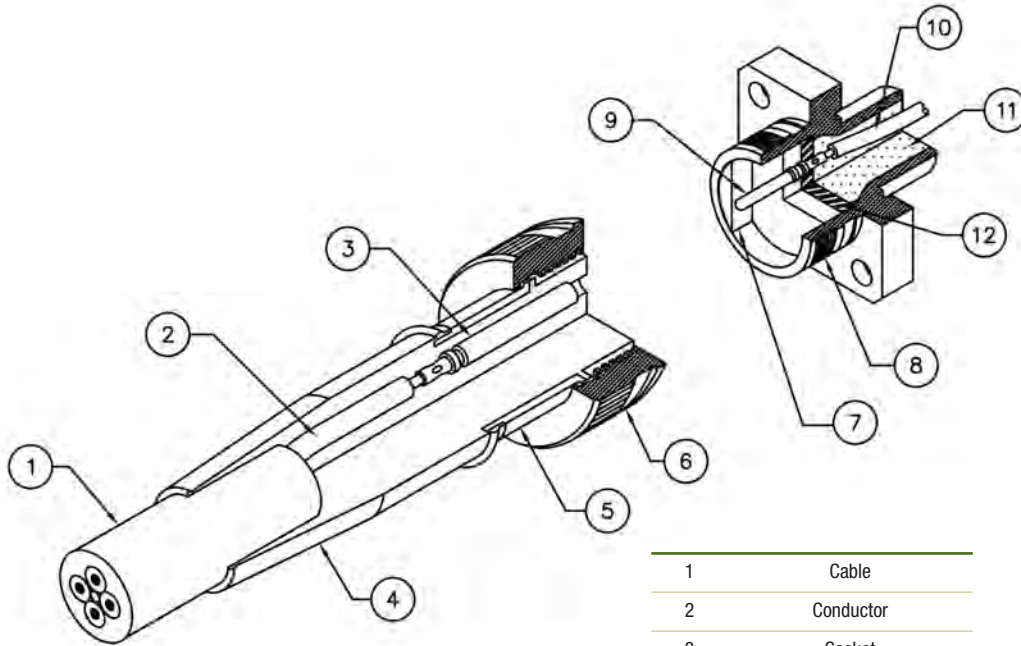

Data and Specifications

Pressure Rating	10,000 PSI
Voltage Rating	600 Volts
Performance Rating	1 GB/SEC (up to 75 meters length)

Materials

Contact	High cond. copper alloy
Shell	316L SS (passivated)
Body	Integrally molded elastomer

1	Cable
2	Conductor
3	Socket
4	Molded Body
5	Metal Shell
6	Locking Ring
7	Keyway
8	Metal Shell
9	Pin
10	Pigtails
11	Epoxy Backfill
12	Pressure Wafer

Ethernet Description	Part Number
Bulkhead Receptacle Shell Size 20, 15	5507-2013-EXXX (Power and Ethernet) 5507-2021-EXXX (Power and Ethernet) 5507-1508-EXXX (Ethernet Only)
Flange Mount Receptacle Shell Size 20	5506-2013-EXXX (Power and Ethernet) 5506-2021-EXXX (Power and Ethernet) 5506-1508-EXXX (Ethernet Only)
Double Ended Plug Shell Size 15 and 20	5999-1049-EXXX (Power and Ethernet) (21 Contacts and 13 Contacts) 5501-1508-EXXX (Single Ended) 5999-XXXX-EXXX (Double Ended)



BURTON

The 5500 Series is an extremely rugged and reliable underwater electrical connector. It is the standard Cooper Interconnect Burton series with pins in the receptacles and sockets in the plugs.

The pin and socket relationship is due to the fact that in most applications, power runs from the plug into the receptacle. For safety reasons, it is desirable never to have power available on the pin side. For reverse power applications, refer to Cooper Interconnect's Burton 6600 series, For over three decades, the Burton 5500 Series has been the industry standard connector for applications which require reliable service in severe situations. The rugged metal shells, recessed pins and face-type seals assure dependable service in the most demanding situations.

Burton SC Series Overview



Molding Bending Strain Relief

Burton SC inline connectors have an integrally molded bending strain relief. Frequently the cable is flexed right at the cable/connector joint. This is because of the sharp change in the modulus of flexure between the cable and connector. A bending strain relief spreads this change over a distance "relieving" the tendency to bend at one specific point. Image shows comparison between typical competitors connectors and Burton SC on right.



Color Coded Leads

Burton SC bulkhead connectors and overmold plugs have color coded leads. The leads are the same color as their mate (the SO cable on the in-line connector). This makes conductor tracing easier and more reliable. Non-Burton SC connectors use a numbered tag on each conductor (which are all the same color, white).

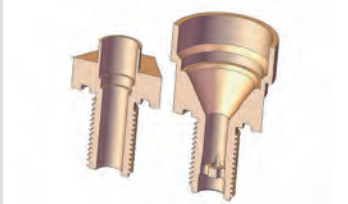

Bulkhead Pressure Block

Burton SC bulkhead connectors have a true pressure block machined into the metal shell. In case of a catastrophic failure, such as part of the bulkhead being sheared off, a pressure block, can sometimes prevent water intrusion into the pressure vessel. Image shows comparison between typical competitors connectors and Burton SC on right.



Improved Overmold Connector

Burton SC has an improved overmold connector which has a much longer sealing area. Additionally, the sealing area has an O-Ring upset to further improve sealing of the boot. Image shows comparison between typical competitors connectors and Burton SC on right.

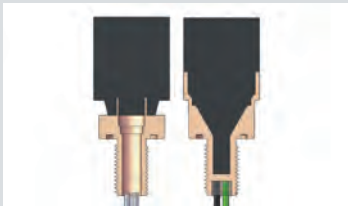

Stronger Neck on Bulkhead

A neck is necessary on this style of connector in order to accommodate the industry standard locking sleeve. On non-Burton SC connectors, it is smaller than necessary. Unfortunately, the head of the bulkhead can therefore be torn off during aggressive disconnection. The neck on the Burton SC bulkhead, however, is heavier, and stronger. Damage to the neck of the bulkhead is a frequent complaint for competitive connectors. Image shows comparison between competitive connectors and Burton SC on right.

Crimped Contacts

Burton SC connectors have crimped contacts. Crimped contacts (rather than soldered) are less susceptible to bending fatigue failures. This type of failure occurs because the solder forces the stranded conductor to become a solid conductor at the joint. Connectors are frequently flexed and sometimes pulled by their cable which causes subtle bending and flexing at the contact joint. Crimped joints hold up to flexing better than soldered joints.

Gold Plated Contacts

Burton SC connectors have gold to reduce the electrical resistance between the pin and socket. Contact resistance can be important in video and digital signal operations. They are not susceptible to normal atmospheric corrosion. Contact corrosion increases contact resistance. Copper and brass contacts corrode right on the shelf. If stored near salt water, such as on a ship, the corrosion can happen quickly. Burton SC contacts are plated to ASTM B488-01 Type II, which supercedes MIL45204C type II grade C.

Pin Shoulder Radius

The Burton SC contact pin and insulation shoulder are both radiused. This makes it easier to mate in darkness or on rough seas. It also reduces the tendency for the shoulder to fray at the pin/shoulder interface, because there is no sharp edge.

Burton SC Series Specifications



BURTON

CI-B H a - 8 B - M P

Contact Type	
MP	Male Pin
FS	Female Socket
HE	Hermaphroditic

Body Size	
M	0.61" OD (mini)
A	.98" OD
B	1.22" OD
C	1.59" OD
L	Low Profile Type

Number of Contacts	
2	
3	
4	
5	
6	
7	
8	
9	
10	
11	
12	
13	
14	
15	
16	

Bulkhead Material (optional)	
a	Aluminum
s	Stainless Steel
t	Titanium

HydroVolt Type	
BH	Bulkhead Connector, Brass
BR	Bulkhead Connector, Right-Angle
DC	Dummy Connector
IL	Inline Connector
IR	Inline Connector, Right-Angle
OM	Overmold Inline Connector
AT	Attachable Inline Connector

Electrical Specs:	
Component	Spec
Contacts, All	600 Volts
Contacts, 2-4	15 Amps
Contacts, 6-8	10 Amps
Ins. Res.	>200 Meg
Hi-Pot	2500 VAC

Color Code:	
Contacts #	Color
1	Black
2	White
3	Red
4	Green
5	Orange
6	Blue
7	White & Black
8	Red & Black
9	Green & Black
10	Orange & Black
11	Blue & Black
12	Black & White
13	Red & White
14	Green & White
15	Blue & White
16	Black & Red

Cable Specs:			
# Cond	V rating	OD	Type
2 Mini	300	0.28	SJO
2 Std	600	0.36	SO
3	600	0.37	SO
4	600	0.40	SO
5	600	0.50	SO
6	600	0.53	SO
8	600	0.60	SO
10	600	.066	SO
12	600	0.66	SO
16	600	0.76	SO

Materials:			
Item	Material	Specifications	Notes
Body	Neoprene	Virgin Electrical Grade	Proprietary Formulation
Bulkheads	Brass	CA-360	Aluminum Optional
Contacts	Brass	CA-360	Gold Plated
Orientation Pin	Brass	CA-360	Gold Plated
Cable	Neoprene	SOW-A	Heavy Duty
Conductors	Teflon	Type E	Color Coded

A-Size

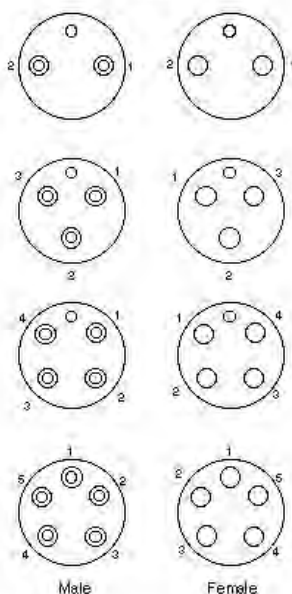

B-Size

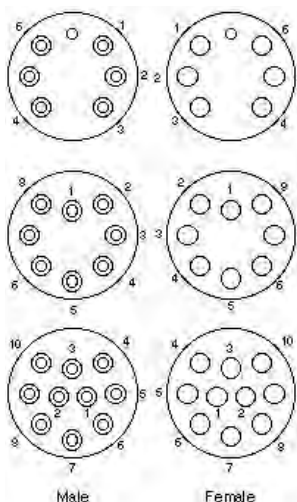

C-Size

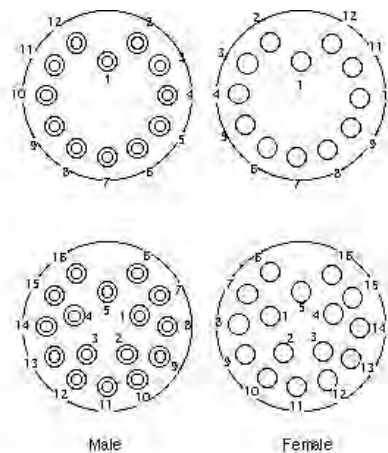

Burton SC Series: A-Size 1" (25mm) Dia.

Burton SC Series A-Size

A-Size has a 1.00 inch (25 mm) diameter form factor. It is the smallest standard size. Contact patterns available include 2, 3, 4, and 5.

Bulkheads

Bulkhead connector receptacles are designed to be mounted to your pressure vessel. They are capable of handling 10,000 psi pressure differential (open face). Bulkheads are available in aluminum, brass, or stainless steel. Other materials can be made by special request.

Inlines

Inline connector plugs are available as pigtails or can be molded onto your cable. The standard pigtail length is 1 meter. However, you may specify any length. Inline connectors plug into a bulkhead receptacle or another inline connector.

PBOF

PBOF / Overmold connectors may be used as PBOF (pressure balanced oil filled) or overmolded inline connectors. There is a groove that fits standard size boots for use as an overmold type.

Overmold

Overmold connectors are for customers who have their own in-house molding capability. The customer may attach almost any type of cable and overmold it to the connector. They have two grooves for tensile strength and a knurled area for rotational strength.

Dummies

Dummy connectors are used to blank off either a bulkhead receptacle, or an inline connector to prevent salt water from touching the gold plated contacts.

Locking Sleeves

Locking sleeves are not necessary for the functionality of Burton SC connectors. However, some customers prefer the assurance that the connectors will not become disengaged by pulling on a cable. Locking sleeves are available in several different materials: Delrin, Aluminum 6061, and Stainless Steel 303. We manufacture our own locking sleeves on a Mori Seiki turning center and so we can easily make them with other materials specified by the customer.

Standard locking sleeves are available with the traditional snap ring groove. They are very convenient for adding a locking sleeve after a bulkhead has been installed, or anytime on a cable assembly. We have snap rings made from Stainless Steel 302, and also Aluminum 6061 (mostly for use with aluminum bulkheads). Aluminum snap rings are much better in contact with aluminum bulkheads for galvanic corrosion reasons. Please see the Technical Notes page for more information about galvanic corrosion. Locking sleeves are also available with a shoulder instead of a snap ring.

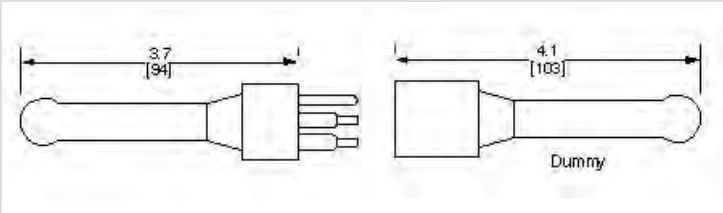
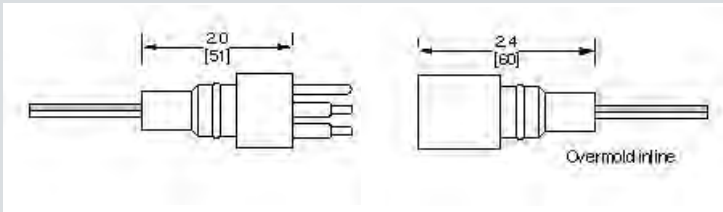
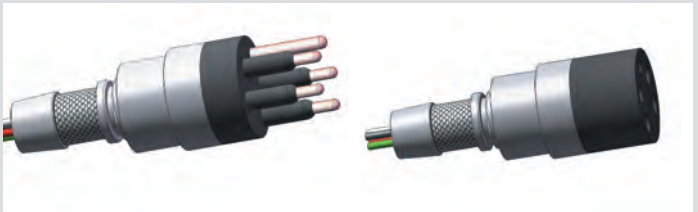
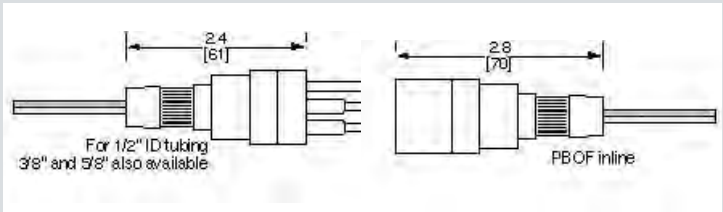
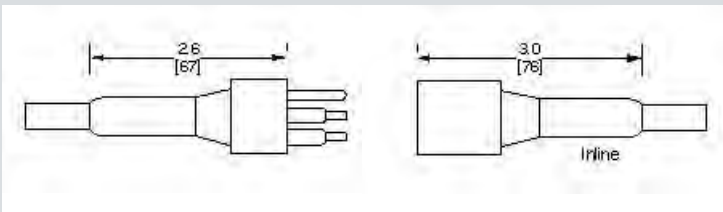
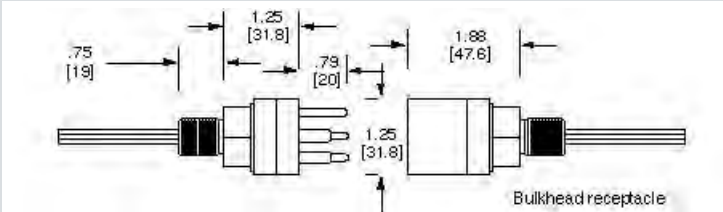

Burton SC Series: B-Size 1.25" (32mm) Dia.

Burton SC Series B-Size

B-size has a 1.25 inch (32 mm) diameter form factor. It is the intermediate standard size. Contact patterns available include 2, 6, 8 and 10.

Bulkheads

Bulkhead connector receptacles are designed to be mounted to your pressure vessel. They are capable of handling 10,000 psi pressure differential (open face). Bulkheads are available in aluminum, brass, or stainless steel. Other materials can be made by special request.

Inlines

Inline connector plugs are available as pigtails or can be molded onto your cable. The standard pigtail length is 1 meter. However, you may specify any length. Inline connectors plug into a bulkhead receptacle or another inline connector.

PBOF

PBOF / Overmold connectors may be used as PBOF (pressure balanced oil filled) or overmolded inline connectors. There is a groove that fits standard size boots for use as an overmold type.

Overmold

Overmold connectors are for customers who have their own in-house molding capability. The customer may attach almost any type of cable and overmold it to the connector. They have two grooves for tensile strength and a knurled area for rotational strength.

Dummies

Dummy connectors are used to blank off either a bulkhead receptacle, or an inline connector to prevent salt water from touching the gold plated contacts.

Locking Sleeves

Locking sleeves are not necessary for the functionality of Burton SC connectors. However, some customers prefer the assurance that the connectors will not become disengaged by pulling on a cable. Locking sleeves are available in several different materials: Delrin, Aluminum 6061, and Stainless Steel 303. We manufacture our own locking sleeves on a Mori Seiki turning center and so we can easily make them with other materials specified by the customer.

Standard locking sleeves are available with the traditional snap ring groove. They are very convenient for adding a locking sleeve after a bulkhead has been installed, or anytime on a cable assembly. We have snap rings made from Stainless Steel 302, and also Aluminum 6061 (mostly for use with aluminum bulkheads). Aluminum snap rings are much better in contact with aluminum bulkheads for galvanic corrosion reasons. Please see the Technical Notes page for more information about galvanic corrosion. Locking sleeves are also available with a shoulder instead of a snap ring.

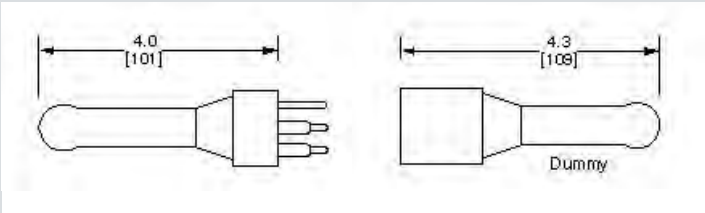
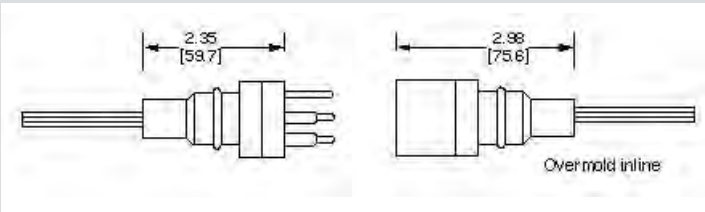
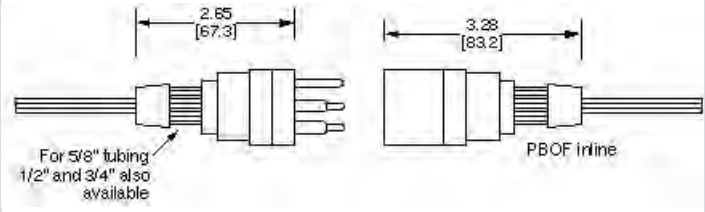
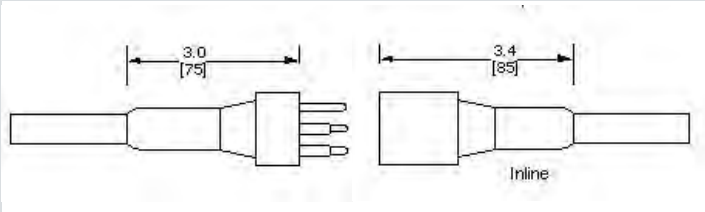
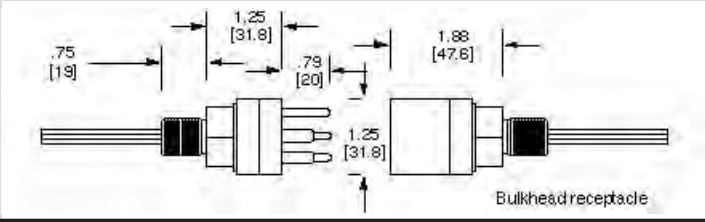

Burton SC Series: C-Size 1.60" (41mm) Dia.

Burton SC Series C-Size

C-Size has a 1.60 inch (41 mm) diameter form factor. It is the largest standard size. Contact patterns available include 12 and 16.

Bulkheads

Bulkhead connector receptacles are designed to be mounted to your pressure vessel. They are capable of handling 10,000 psi pressure differential (open face). Bulkheads are available in aluminum, brass, or stainless steel. Other materials can be made by special request.

Inlines

Inline connector plugs are available as pigtails or can be molded onto your cable. The standard pigtail length is 1-meter. However, you may specify any length. Inline connectors plug into a bulkhead receptacle or another inline connector.

Dummies

Dummy connectors are used to blank off either a bulkhead receptacle, or an inline connector to prevent salt water from touching the gold plated contacts.

Locking Sleeves

Locking sleeves are not necessary for the functionality of Burton SC connectors. However, some customers prefer the assurance that the connectors will not become disengaged by pulling on a cable. Locking sleeves are available in several different materials: Delrin, Aluminum 6061, and Stainless Steel 303. We manufacture our own locking sleeves on a Mori Seiki turning center and so we can easily make them with other materials specified by the customer.

Standard locking sleeves are available with the traditional snap ring groove. They are very convenient for adding a locking sleeve after a bulkhead has been installed, or anytime on a cable assembly. We have snap rings made from Stainless Steel 302, and also Aluminum 6061 (mostly for use with aluminum bulkheads). Aluminum snap rings are much better in contact with aluminum bulkheads for galvanic corrosion reasons. Please see the Technical Notes page for more information about galvanic corrosion. Locking sleeves are also available with a shoulder instead of a snap ring.

BURTON SC

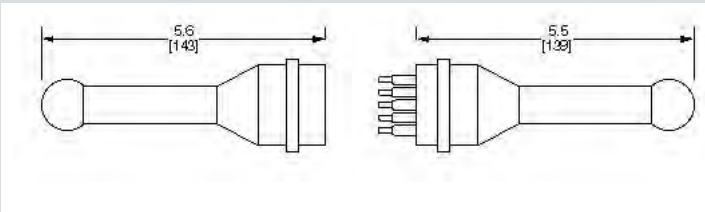
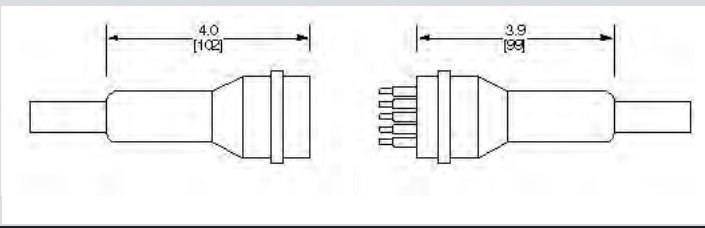
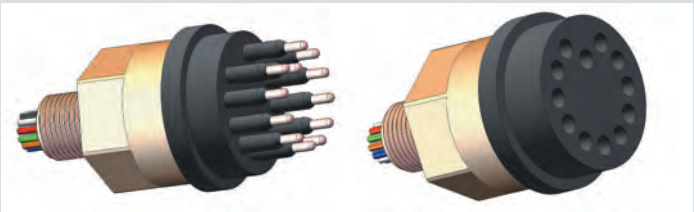
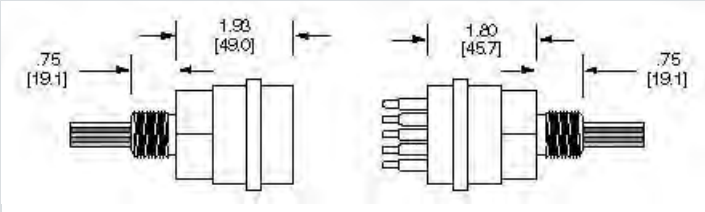

Series 51 Male Connector—"Underwater Pluggable"



FEATURES:

- Exclusive construction of these patented WATERMATE™ electrical connectors permits underwater plugging and unplugging with electrical power de-energized.
- Pressure rated up to 20,000 psi or maximum 45,000 feet of sea water (except Series 53 which is rated up to 10,000 psi).
- Pressure balanced for easy engagement and disengagement in high-pressure environments.

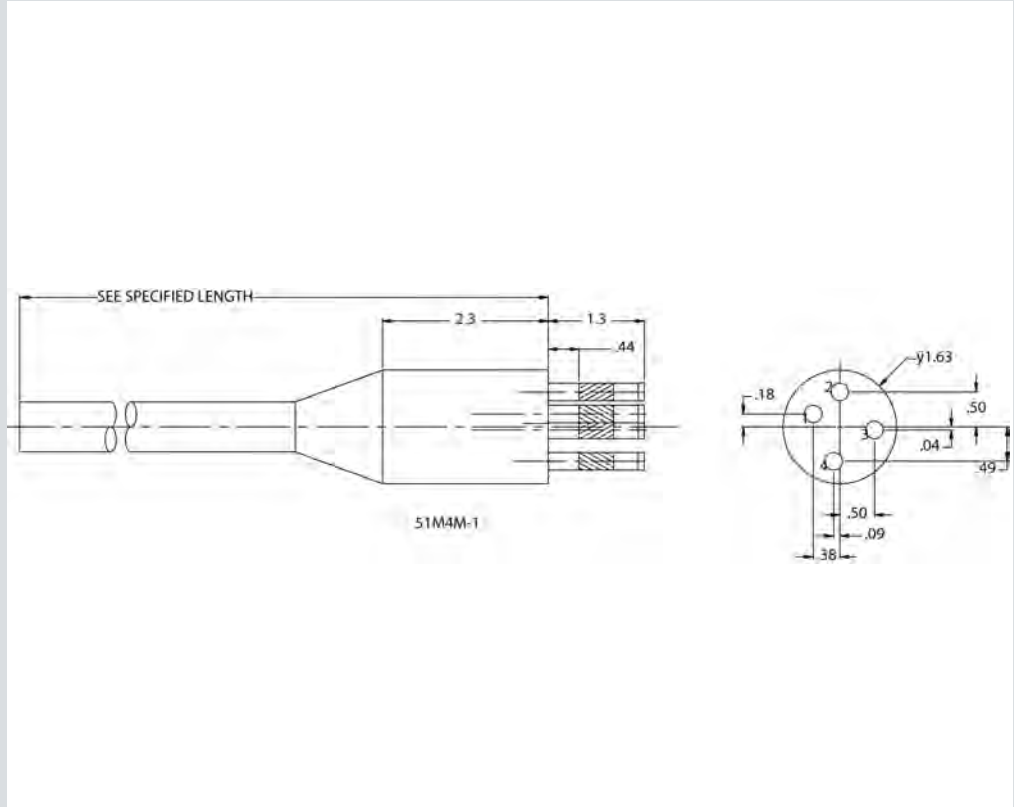

Model	No. of Contacts	No. of Pins	Max Volts	Contacts Per Pin	Rating Amps ¹	Wire Size AWG	A In.	B In.	D In.	L ±1 In.	Mates With Model ²
51E1M-1	1	1	230	1	15	16	.44	1.0	2.0	24	51E1F, 53E1F, 59E1F, Series 54 & 84 J Box
51E1M-80	1	1	230	1	15	16	.63	1.56	2.56	24	51E1F, 53E1F, 59E1F, Series 54 & 84 J Box
51H1M-1	1	1	440	1	60	8	1.0	1.5	3.5	36	51H1F, 53H1F, Series 54J Box
51E2M-1	2	2	230	1	15	16	1.0	.75	1.75	24	51E2F, 53E2F, Series 54J Box
51F2M-1	2	1	115	2	7.5	18	.44	1.0	2.0	24	51F2F, 53F2F, 59F2F, Series 54 & 84 J Box
51F2M-50	2	1	115	2	7.5	18	.63	1.56	2.56	24	51F2F, 53F2F, 59F2F, Series 54 & 84 J Box
51E3M-1	3	3	230	1	15	16	1.0	.75	1.75	24	51E3F, 53E3F, Series 54J Box
51H3M-1	3	3	440	1	60	6	2.0	1.50	3.50	36	51H3F, 53H3F, Series 54J Box
51L3M-1	3	3	440	1	100	4	2.5	2.0	4.38	36	51L3F, 53L3F, Series 54J Box
51E4M-1	4	4	230	1	15	16	1.25	.75	1.75	24	51E4F, 53E4F, Series 54J Box
51F4M-1	4	2	115	2	7.5	18	1.0	.75	1.75	24	51F4F, 53F4F, Series 54J Box
51H4M-1	4	4	440	1	60	6	2.0	1.5	3.5	36	51H4F, 53H4F, Series 54J Box
51L4M-1	4	4	440	1	85	4	2.5	2.0	4.38	36	51L4F, 53L4F, Series 54J Box
51F6M-1	6	3	115	2	7.5	18	1.25	.75	1.75	36	51F6F, 53F6F, Series 54J Box
51F8M-1	8	4	115	2	7.5	18	1.25	.75	1.75	36	51F8F, 53F8F, Series 54J Box

Unless otherwise specified dimensions are nominal.

¹ Per contact.

² Add DO for dummy connector, all circuits open.

Add DS for dummy connector, all circuits shorted or paired as indicated.

Series 51 Female Connector



ELECTRO OCEANIC

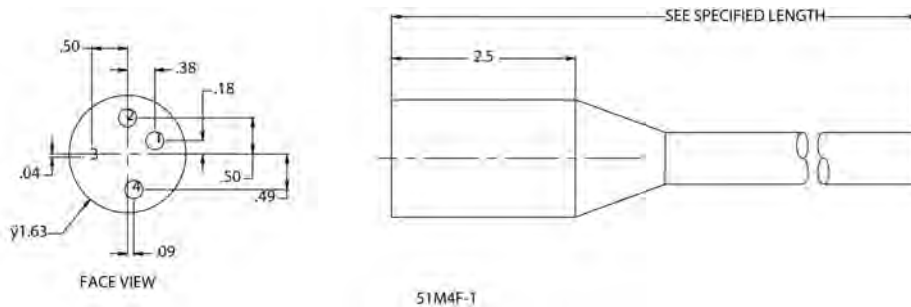

Some typical uses of underwater pluggable WATERMATE™ Plugs, Receptacles and Connectors are in power and/or control circuits for:

- Underwater instrumentation and control packages
- Underwater cameras
- Sonar equipment
- Underwater electrical power distribution systems
- Underwater lighting systems

These underwater applications are frequently found in:

- Diving bells
- Submarines
- Ships
- Diving helmets
- Submersible pumps

For offshore marine installation of moorings, dock facilities, petroleum production platforms, etc.

Model	No. of Contacts	Max Volts	Rating Amps ¹	Wire Size AWG	A In.	B In.	L ±1 In.	Mates With ²
51E1F-1	1	230	15	16	.56	1.13	24	51E1M, 53E1M, 59E1M
51E1F-80	1	230	15	16	.63	1.56	24	51E1M, 53E1M, 59E1M
51H1F-1	1	440	60	8	1.0	3.75	36	51H1M, 53H1M
51E2F-1	2	230	15	16	1.0	1.13	24	51E2M, 53E2M
51F2F-1	2	115	7.5	18	.44	1.13	24	51M2M, 53M2M, 59M2M
51F2F-50	2	115	7.5	18	.63	1.56	24	51M2M, 53M2M, 59M2M
51E3F-1	3	230	15	16	1.0	1.13	24	51E3M, 53E3M
51H3F-1	3	440	60	6	2.0	2.25	36	51H3M, 53H3M
51L3F-1	3	440	100	4	2.5	2.38	36	51L3M, 53L3M
51E4F-1	4	230	15	16	1.25	1.13	24	51E4M, 53E4M
51F4F-1	4	115	7.5	18	1.0	1.13	24	51M4M, 53M4M
51H4F-1	4	440	60	6	2.0	2.25	36	51H4M, 53H4M
51L4F-1	4	440	85	4	2.5	2.38	36	51L4M, 53L4M
51F6F-1	6	115	7.5	18	1.25	1.13	36	51M6M, 53M6M
51F8F-1	8	115	7.5	18	1.25	1.13	36	51M8M, 53M8M

Unless otherwise specified dimensions are nominal.

¹ Per contact.

² Add DO for dummy connector, all circuits open.

Add DS for dummy connector, all circuits shorted or paired as indicated.

Series B51 Female Connector



ELECTRO OCEANIC

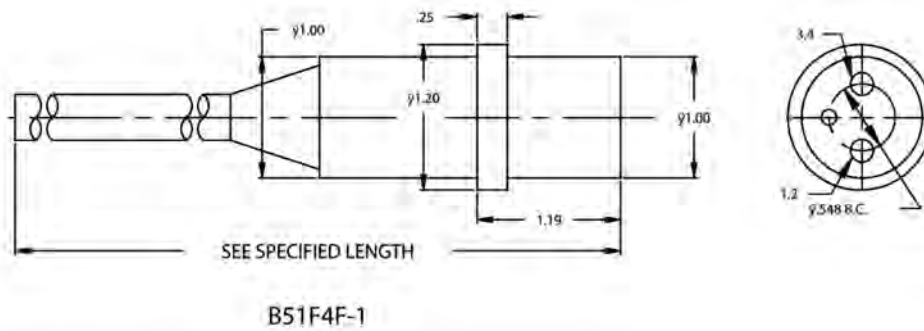

Some typical uses of underwater pluggable WATERMATE™ Plugs, Receptacles and Connectors are in power and/or control circuits for:

- Underwater instrumentation and control packages
- Underwater cameras
- Sonar equipment
- Underwater electrical power distribution systems
- Underwater lighting systems

These underwater applications are frequently found in:

- Diving bells
- Submarines
- Ships
- Diving helmets
- Submersible pumps

For offshore marine installation of moorings, dock facilities, petroleum production platforms, etc.

Model	No. of Contacts	No. of Pins	Max Volts	Wire Size AWG	Rating Amps ¹	A Dia.	B Dia.	C	D	E	L ±1 In.	Mates With ²
B51E1F-1	1	1	230	16	15	.63	.83	.25	1.19	2.50	36	B51E1M-1, B53E1M-1
B51L1F-1	1	1	440	16	175	1.25	1.45	.25	1.19	4.13	36	B51L1M-1, B53L1M-1
B51E2F-1	2	2	230	16	15	1.00	1.20	.25	1.19	2.50	36	B51E2M-1, B53E2M-1
B51F2F-1	2	1	115	18	7.5	.63	.83	.25	1.19	2.50	36	B51F2M-1, B53F2M-1
B51E3F-1	3	3	230	16	15	1.00	1.20	.25	1.19	2.50	36	B51E3M-1, B53E3M-1
B51L3F-1	3	3	440	4	100	2.50	3.00	.38	2.75	5.00	36	B51L3M-1, B53L3M-1
B51E4F-1	4	4	230	16	15	1.25	1.45	.25	1.19	2.50	36	B51E4M-1, B53E4M-1
B51F4F-1	4	2	115	18	7.5	1.00	1.20	.25	1.19	2.50	36	B51F4M-1, B53F4M-1
B51H4F-1	4	4	440	4	100	2.50	3.00	.38	2.75	5.00	36	B51L4M-1, B53L4M-1
B51F6F-1	6	3	115	18	7.5	1.25	1.45	.25	1.19	2.50	36	B51F6M-1, B53F6M-1
B51F8F-1	8	4	115	18	7.5	1.25	1.45	.25	1.19	2.50	36	B51F8M-1, B53F8M-1

Unless otherwise specified dimensions are nominal.

¹ For DO and DS dummy connectors, see 51 Series, pages 34 & 35.

² Per contact.

Series 53 Male Connector



FEATURES:

- Exclusive construction of these patented WATERMATE™ electrical connectors permits underwater plugging and unplugging with electrical power de-energized.
- Pressure rated up to 20,000 psi or maximum 45,000 feet of sea water (except Series 53 which is rated up to 10,000 psi).
- Pressure balanced for easy engagement and disengagement in high-pressure environments.

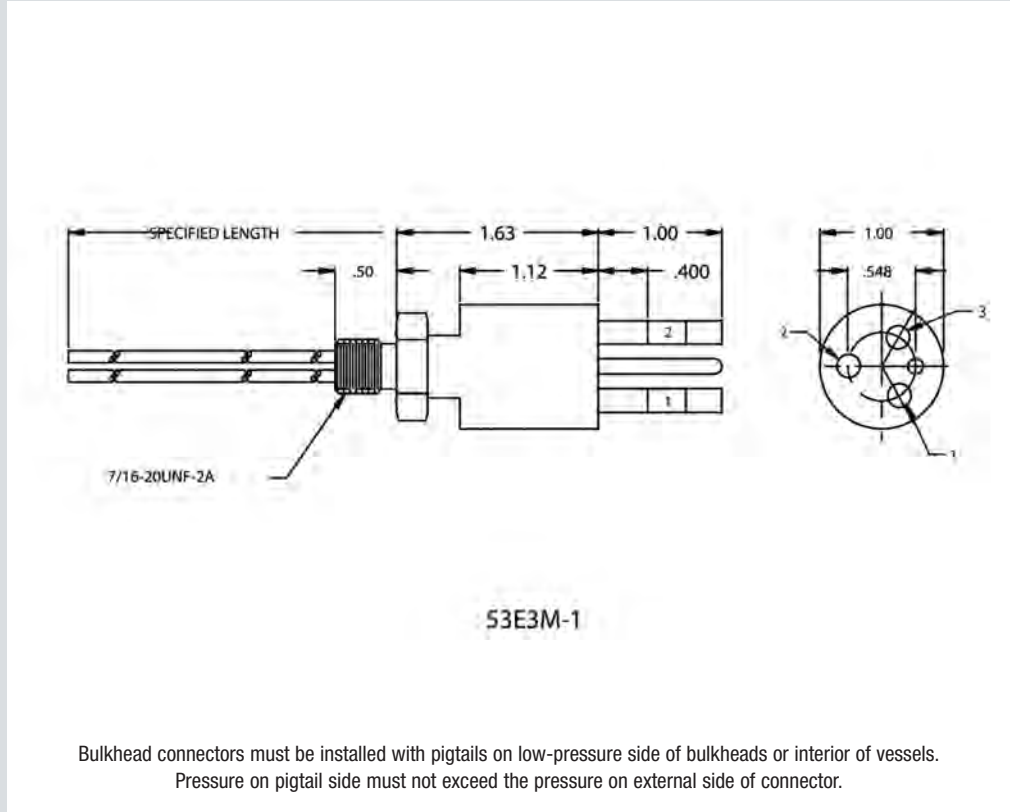

Bulkhead connectors must be installed with pigtails on low-pressure side of bulkheads or interior of vessels. Pressure on pigtail side must not exceed the pressure on external side of connector.

Model	No. of Contacts	No. of Pins	Max Volts	Contacts Per Pin	Wire Size AWG	Rating Amps ¹	A In.	B In.	C In.	D In.	E	F	L ±1 In.	N	P ±1/32 In.	Mates With ²
53E1M-1	1	1	230	1	16	15	.63	.63	1.13	2.13	7/16-20	2-014	12	.75	.50	51E1F
53H1M-1	1	1	440	1	8	60	1.00	1.81	2.38	4.38	3/4-16	2-019	12	1.13	.75	51H1F
53E2M-1	2	2	230	1	16	15	1.00	1.13	1.63	2.63	7/16-20	2-014	12	.75	.50	51E2F
53F2M-1	2	1	115	2	18	7.5	.63	.63	1.13	2.13	7/16-20	2-014	12	.75	.50	51F2F
53E3M-1	3	3	230	1	16	15	1.00	1.13	1.63	2.63	7/16-20	2-014	12	.75	.50	51E3F
53H3M-1	3	3	440	1	8	60	2.00	2.50	3.13	5.13	1-1/4-12	2-125	12	1.75	1.25	51H3F
53L3M-1	3	3	440	1	4	100	2.50	3.38	3.88	6.25	1-3/4-12	2-136	12	2.50	1.50	51L3F
53E4M-1	4	4	230	1	16	15	1.25	1.13	1.63	2.63	1/2-20	2-015	12	.88	.50	51E4F
53F4M-1	4	2	115	2	18	7.5	1.00	1.13	1.63	2.63	7/16-20	2-014	12	.75	.50	51F4F
53H4M-1	4	4	440	1	8	60	2.00	2.50	3.13	5.13	1-1/4-12	2-125	12	1.75	1.25	51H4F
53L4M-1	4	4	440	1	4	100	2.50	3.38	3.88	6.25	1-3/4-12	2-136	12	2.50	1.50	51L4F
53F6M-1	6	3	115	2	18	7.5	1.25	1.13	1.63	2.63	1/2-20	2-015	12	.88	.50	51F6F
53F8M-1	8	4	115	2	18	7.5	1.25	1.13	1.63	2.63	1/2-20	2-015	12	.88	.50	51F8F

Unless otherwise specified dimensions are nominal.

¹ Per contact.

² For DO and DS dummy connectors, see 51 Series, page 34 & 35.

Series 53 Female Connector

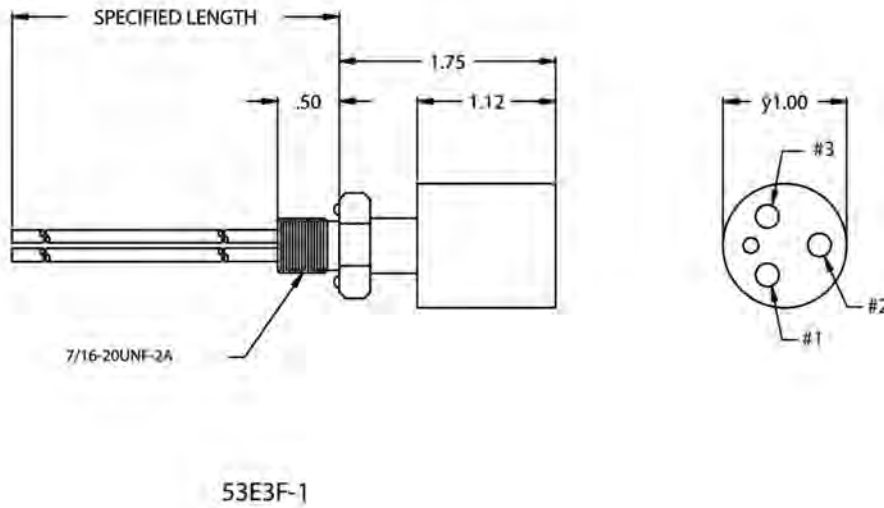

Bulkhead connectors must be installed with pigtails on low-pressure side of bulkheads or interior of vessels.
Pressure on pigtail side must not exceed the pressure on external side of connector.



Some typical uses of underwater pluggable WATERMATE™ Plugs, Receptacles and Connectors are in power and/or control circuits for:

- Underwater instrumentation and control packages
- Underwater cameras
- Sonar equipment
- Underwater electrical power distribution systems
- Underwater lighting systems

These underwater applications are frequently found in:

- Diving bells
- Submarines
- Ships
- Diving helmets
- Submersible pumps

For offshore marine installation of moorings, dock facilities, petroleum production platforms, etc.

ELECTRO OCEANIC

Model	No. of Contacts	Max Volts	Wire Size AWG	Rating Amps	A In.	B In.	C In.	E	F	L ±1 In.	N	P ±1/32 In.	Mates With
53E1F-1	1	230	16	15	.63	1.50	2.00	7/16-20	2-014	12	.75	.50	51E1M
53H1F-1	1	440	8	60	1.00	2.94	3.50	3/4-16	2-019	12	1.13	.75	51H1M
53E2F-1	2	230	16	15	1.00	1.13	1.75	7/16-20	2-014	12	.75	.50	51E2M
53F2F-1	2	115	18	7.5	.63	1.50	2.00	7/16-20	2-014	12	.75	.50	51F2M
53E3F-1	3	230	16	15	1.00	1.13	1.75	7/16-20	2-014	12	.75	.50	51E3M
53H3F-1	3	440	8	60	2.00	2.38	3.00	1-1/4-12	2-125	12	1.75	1.25	51H3M
53L3F-1	3	440	4	100	2.50	3.38	3.88	1-3/4-12	2-136	12	2.50	1.50	51L3M
53E4F-1	4	230	16	15	1.25	1.13	2.00	1/2-20	2-015	12	.88	.50	51E4M
53F4F-1	4	115	18	7.5	1.00	1.13	1.75	7/16-20	2-014	12	.75	.50	51F4M
53H4F-1	4	440	8	60	2.00	2.38	3.00	1-1/4-12	2-125	12	1.75	1.25	51H4M
53L4F-1	4	440	4	100	2.50	3.38	3.88	1-3/4-12	2-136	12	2.50	1.50	51L4M
53F6F-1	6	115	18	7.5	1.25	1.13	2.00	1/2-20	2-015	12	.88	.50	51M6M
53F8F-1	8	115	18	7.5	1.25	1.13	2.00	1/2-20	2-015	12	.88	.50	51M8M

Unless otherwise specified dimensions are nominal.

¹ Per contact.

² For DO and DS dummy connectors, see 51 Series, page 34 & 35.

Series B53 Male Connector



FEATURES:

- Exclusive construction of these patented WATERMATE™ electrical connectors permits underwater plugging and unplugging with electrical power de-energized.
- Pressure rated up to 20,000 psi or maximum 45,000 feet of sea water (except Series 53 which is rated up to 10,000 psi).
- Pressure balanced for easy engagement and disengagement in high-pressure environments.

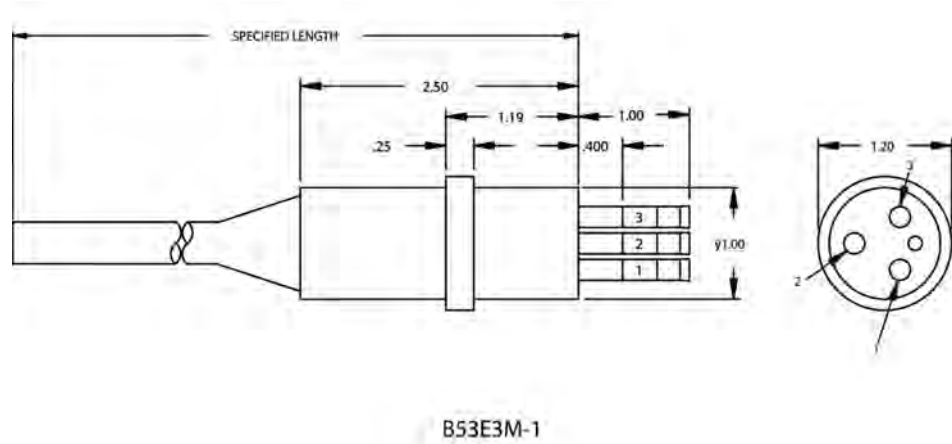

Model	No. of Contacts	No. of Pins	Max Volts	Wire Size AWG	Rating Amps ²	A In.	B In.	C In.	D In.	E	F	O	L ±1 In.	P	T	N	Mates With ¹
B53E1M-1	1	1	230	16	15	.63	.83	.25	1.19	2.00	3.00	2-015	12	.50	1/2-20 UNF	.88	B51E1F-1
B53L1M-1	1	1	440	1	175	1.25	1.45	.25	1.19	2.50	4.88	2-122	12	1.00	1-14 UNF	1.50	B51H1F-1
B53E2M-1	2	2	230	16	15	1.00	1.20	.25	1.19	2.00	3.00	2-015	12	.50	1/2-20 UNF	.88	B51E2F-1
B53F2M-1	2	1	115	18	7.5	.63	.83	.25	1.19	2.00	3.00	2-015	12	.50	1/2-20 UNF	.88	B51F2F-1
B53E3M-1	3	3	230	16	15	1.00	1.20	.25	1.19	2.00	3.00	2-015	12	.50	1/2-20 UNF	.88	B51E3F-1
B53L3M-1	3	3	440	4	100	2.50	3.00	.38	1.88	5.00	6.38	2-136	12	1.50	1-3/4-12 UNF	2.50	B51L3F-1
B53E4M-1	4	4	230	16	15	1.25	1.45	.25	1.19	2.00	3.00	2-019	12	.75	3/4-16 UNF	1.13	B51E4F-1
B53F4M-1	4	2	115	18	7.5	1.00	1.20	.25	1.19	2.00	3.00	2-015	12	.50	1/2-20 UNF	.88	B51F4F-1
B53L4M-1	4	4	440	4	100	2.50	3.00	.38	1.88	5.00	6.38	2-136	12	1.50	1-3/4-12 UNF	2.50	B51L4F-1
B53F6M-1	6	3	115	18	7.5	1.25	1.45	.25	1.19	2.00	3.00	2-019	12	.75	3/4-16 UNF	1.13	B51F6F-1
B53F8M-1	8	4	115	18	7.5	1.25	1.45	.25	1.19	2.00	3.00	2-019	12	.75	3/4-16 UNF	1.13	B51F8F-1

Unless otherwise specified dimensions are nominal.

¹ For DO and DS dummy connectors, see 51 Series, page 34 & 35.

² Per contact.

Series B53 Female Connector

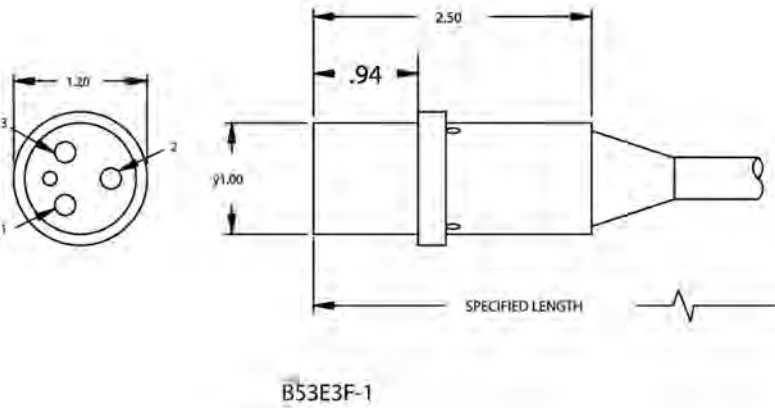

ELECTRO OCEANIC

Some typical uses of underwater pluggable WATERMATE™ Plugs, Receptacles and Connectors are in power and/or control circuits for:

- Underwater instrumentation and control packages
- Underwater cameras
- Sonar equipment
- Underwater electrical power distribution systems
- Underwater lighting systems

These underwater applications are frequently found in:

- Diving bells
- Submarines
- Ships
- Diving helmets
- Submersible pumps

For offshore marine installation of moorings, dock facilities, petroleum production platforms, etc.

Model	No. of Contacts	Max Volts	Wire Size AWG	Rating Amps	A In.	B In.	C In.	D In.	E	O	L ±1 In.	P	T	N	Mates With
B53E1F-1	1	230	16	15	.63	.83	.25	1.19	2.31	2-015	12	.50	1/2-20 UNF	.88	B51E1M-1
B53L1F-1	1	440	1	175	1.25	1.95	.25	1.19	5.13	2-122	12	1.00	1-14 UNF	1.50	B51H1M-1
B53E2F-1	2	230	16	15	1.00	1.20	.25	1.19	2.31	2-015	12	.50	1/2-20 UNF	.88	B51E2M-1
B53F2F-1	2	115	18	7.5	.63	.83	.25	1.19	2.31	2-015	12	.50	1/2-20 UNF	.88	B51F2M-1
B53E3F-1	3	230	16	15	1.00	1.20	.25	1.19	2.31	2-015	12	.50	1/2-20 UNF	.88	B51E3M-1
B53L3F-1	3	440	4	100	2.50	3.00	.38	2.75	6.50	2-136	12	1.50	1-3/4-12 UNF	2.50	B51L3M-1
B53E4F-1	4	230	16	15	1.25	1.45	.25	1.19	2.31	2-019	12	.75	3/4-16 UNF	1.13	B51E4M-1
B53F4F-1	4	115	18	7.5	1.00	1.20	.25	1.19	2.31	2-015	12	.50	1/2-20 UNF	.88	B51F4M-1
B53L4F-1	4	440	4	100	2.50	3.00	.38	1.88	5.00	2-136	12	1.50	1-3/4-12 UNF	2.50	B51L4M-1
B53F6F-1	6	115	18	7.5	1.25	1.45	.25	1.19	2.31	2-019	12	.75	3/4-16 UNF	1.13	B51F6M-1
B53F8F-1	8	115	18	7.5	1.25	1.45	.25	1.19	2.31	2-019	12	.75	3/4-16 UNF	1.13	B51F8M-1

Unless otherwise specified dimensions are nominal.

¹ For D0 and DS dummy connectors, see 51 Series, page 34 & 35.

² Per contact.

Series 59 Pin Male/Female Right Angle Connectors



FEATURES:

- Series 59 right angle receptacles are designed for bulkhead mounting where space is limited. Exclusive construction of these patented WATERMATE™ electrical connectors permits underwater plugging and unplugging with electrical power de-energized.
- Pressure rated up to 10,000 psi or maximum 22,000 feet of seawater. (Optional to 20,000 psi)
- Pressure balanced for easy engagement and disengagement in high-pressure environments.
- Body is specially formulated neoprene rubber. Contacts are beryllium copper.
- Electrical specification similar to Series 51 and 53.

Some typical uses of underwater pluggable WATERMATE™ Plugs, Receptacles and Connectors are in power and/or control circuits for:

- Underwater instrumentation and control packages
- Underwater cameras
- Sonar equipment
- Underwater electrical power distribution systems
- Underwater lighting systems

These underwater applications are frequently found in:

- Diving bells
- Submarines
- Ships
- Diving helmets
- Submersible pumps

For offshore marine installation of moorings, dock facilities, petroleum production platforms, etc.

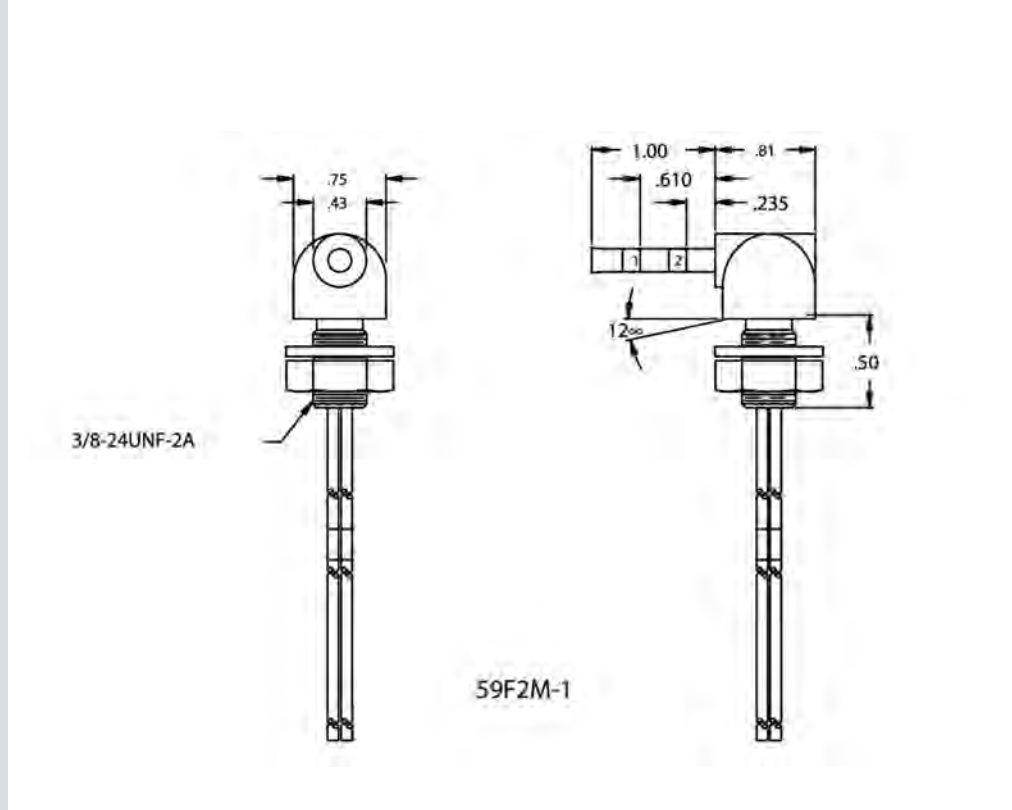

Model	No. of Circuits	No. of Pins or Sockets	Max Volts	Pin or Socket Dia. Inches	Circuits Per Pin or Socket	Amps per Connector (Max.)	Wire Size AWG	P ±1/32 In.	B In.	D In.	E Thread	Mates With Shell ¹
59F2M or F-1	2	1	115	.188	2	7.5	18	.50	.81	1.81	3/8-24	51F2F or M
59F2M or F-2	2	1	115	.188	2	7.5	18	.75	.81	1.81	3/8-24	51F2F or M
59F2M or F-3	2	1	115	.188	2	7.5	18	1.0	.81	1.81	3/8-24	51F2F or M
59F2M or F-4	2	1	115	.188	2	7.5	18	.50	.81	1.81	7/16-20	51F2F or M
59F2M or F-5	2	1	115	.188	2	7.5	18	.75	.81	1.81	7/16-20	51F2F or M
59F2M or F-6	2	1	115	.188	2	7.5	18	1.0	.81	1.81	7/16-20	51F2F or M

Unless otherwise specified dimensions are nominal.

¹ Physical dimensions for 59E1F or 59E1M-1 thru 6 are the same as those listed above for – 1 through 6. Electrical ratings for 59E Series are listed on page 35.

Series 510 Two Pin Connector

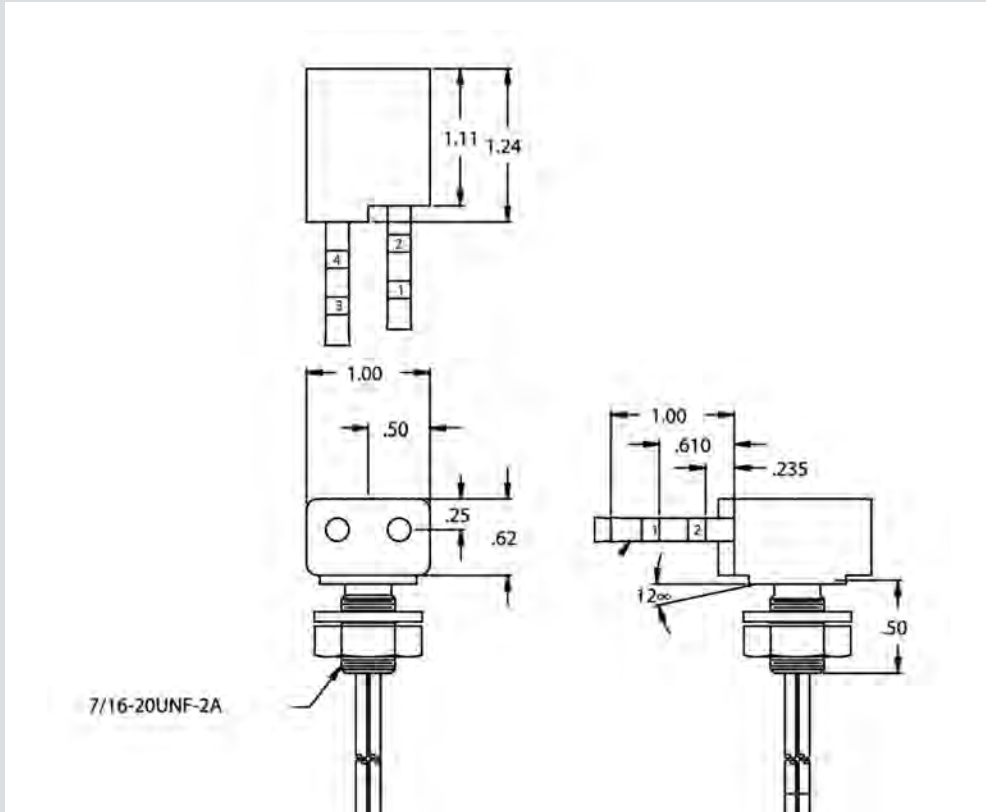

FEATURES:

- Series 510 right angle receptacles are designed for bulkhead mounting where space is limited. Exclusive construction of these patented WATER-MATE™ electrical connectors permits underwater plugging and unplugging with electrical power de-energized.
- Pressure rated up to 5,000 psi or equivalent to maximum 11,000 feet of seawater. (Optionally available to 20,000 psi)
- Pressure balanced for easy engagement and disengagement in high-pressure environments.
- Body is specially formulated neoprene rubber. Contacts are beryllium copper.
- Longer shanks (P) and pigtail (L) lengths are optionally available.
- Electrical specification similar to Series 51 and 53.

Some typical uses of underwater pluggable WATERMATE™ Plugs, Receptacles and Connectors are in power and/or control circuits for:

- Underwater instrumentation and control packages
- Underwater cameras
- Sonar equipment
- Underwater electrical power distribution systems
- Underwater lighting systems

These underwater applications are frequently found in:

- Diving bells
- Submarines
- Ships
- Diving helmets
- Submersible pumps

For offshore marine installation of moorings, dock facilities, petroleum production platforms, etc.

ELECTRO OCEANIC

Model	No. of Circuits	No. of Pins or Sockets	M	U	F	Max Volts	Circuits Per Pin or Socket	Amps per Connector (Max.)	Wire Size AWG	P ±1/32 In.	L In.	E Thread	Mates With	Model	No. of Circuits
510E2M or F or U-4	2	1	1/1	1	230	1	15	16	.50	12	7/16-20	52E2F or M or U-1	510E2M or F or U-4	2	
510E2M or F or U-5	2	1	1/1	1	230	1	15	16	.75	12	7/16-20	52E2F or M or U-1	510E2M or F or U-5	2	
510E2M or F or U-6	2	1	1/1	1	230	1	15	16	1.0	12	7/16-20	52E2F or M or U-1	510E2M or F or U-6	2	
510F4M or F or U-4	4	1	1/1	1	115	2	7.5	18	.50	12	7/16-20	52F4F or M or U-1	510F4M or F or U-4	4	
510F4M or F or U-5	4	1	1/1	1	115	2	7.5	18	.75	12	7/16-20	52F4F or M or U-1	510F4M or F or U-5	4	
510F4M or F or U-6	4	1	1/1	1	115	2	7.5	18	1.0	12	7/16-20	52F4F or M or U-1	510F4M or F or U-6	4	

Unless otherwise specified dimensions are nominal.

Series 52 Two Pin Male/Female/Universal Connector



FEATURES:

- Exclusive construction of these patented WATERMATE™ electrical connectors permits underwater plugging and unplugging with electrical power de-energized.
- Pressure rated up to 20,000 psi or equivalent to maximum 45,000 feet of seawater.
- Pressure balanced for easy engagement and disengagement in high pressure.
- Body is specially formulated neoprene rubber. Contacts are beryllium copper.
- Electrical specification similar to Series 51 and 53.

Some typical uses of underwater pluggable WATERMATE™ Plugs, Receptacles and Connectors are in power and/or control circuits for:

- Underwater instrumentation and control packages
- Underwater cameras
- Sonar equipment
- Underwater electrical power distribution systems
- Underwater lighting systems

These underwater applications are frequently found in:

- Diving bells
- Submarines
- Ships
- Diving helmets
- Submersible pumps

For offshore marine installation of moorings, dock facilities, petroleum production platforms, etc.

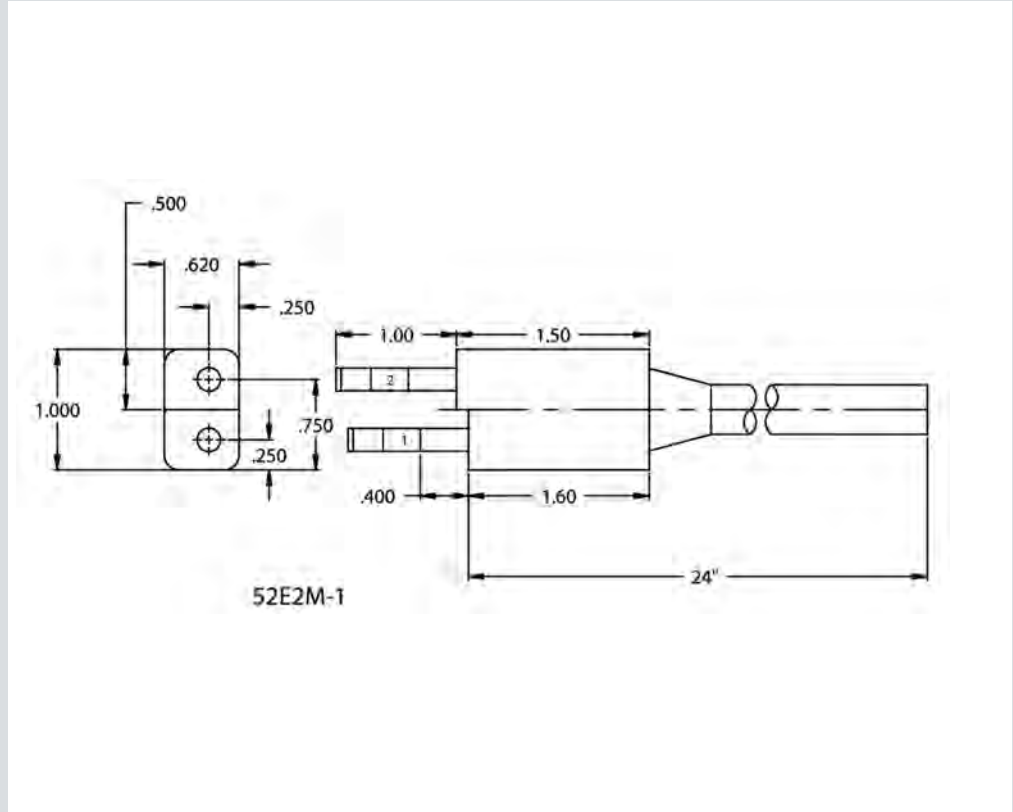

Model	No. of Circuits	No. of Pins or Sockets			Max Volts	Circuits Per Pin or Socket	Amps per Connector (Max.)	Wire Size AWG	D In.	L ±1 In.	Mates With
		M	U	F							
52E2M or F or U-1	2	2	2/2	2	230	1	15	16	2.50	24	52E2F or M or U, 510E2F or M or U
52F4M or F or U-1	4	2	2/2	2	115	2	7.5	18	2.50	24	52E4F or M or U, 510E4F or M or U

Unless otherwise specified dimensions are nominal.

Series 610 Waterproof Switches



ELECTRO OCEANIC

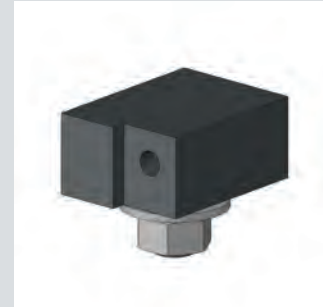
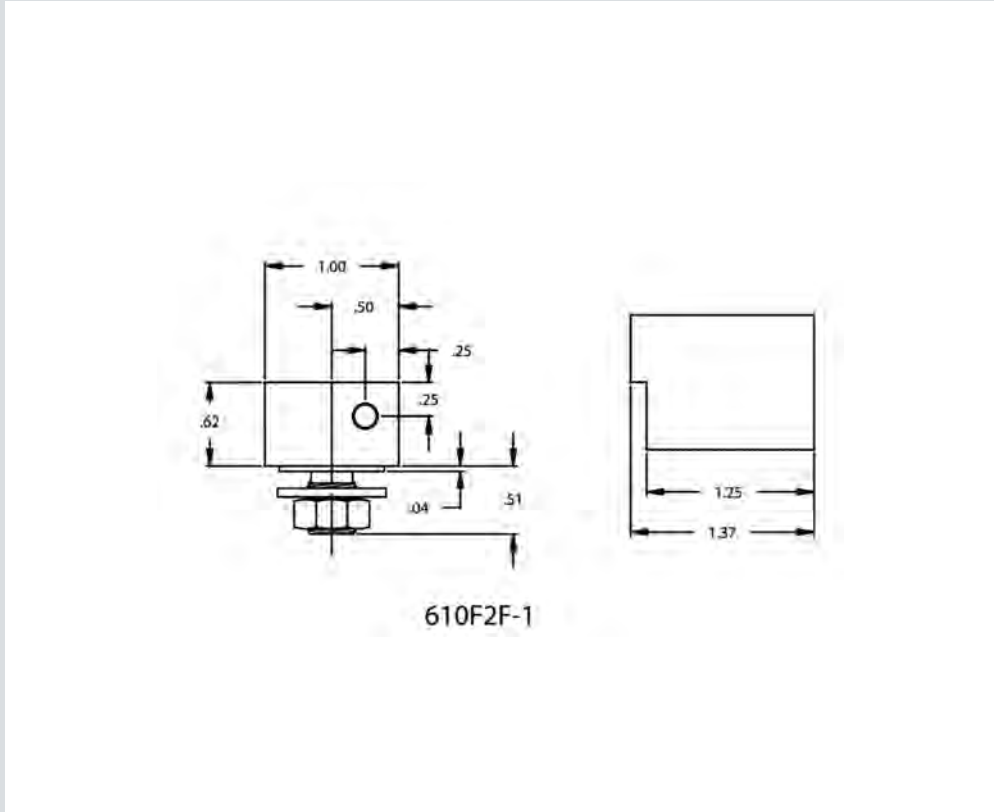

Magnetically operated switches are designed for resistance to water and oily environments.

Connection is made through an underwater pluggable connector. Operation is by remote magnet.



Model	Contact Rating	Max Amps	Max Volts	Max Contact Resistance	Voltage Breakdown	Mates With
610F2F-1 Brass	10 w dc	0.5	200	0.100 ohm	400 vdc	51F2M
610F2F-L1 Stainless Steel	10 w dc	0.5	200	0.100 ohm	400 vdc	51F2M

Unless otherwise specified dimensions are nominal.

CONSTRUCTION DETAILS

SWITCH

Contact arrangement: SPST-NO
Contact material: Rhodium Standard

ENCLOSURE

Internal construction: Switch potted in Micarta base block, screw attached to brass mounting stud.
Stud mounting: 3/8" - 24, 1/2" long with 3/8" washer and 3/8" - 24 hex nut.
Enclosure: Specially formulated neoprene rubber, nonwetting surface.
Insulation resistance: 100 megohms contact-to-contact in water.

SWITCH ELECTRICAL SPECIFICATIONS

Insulation resistance: 100 megohms.
Life expectancy: 10 x 10⁶, full rating.
Contact rating: 10 w dc, 0.5 amp max.
Actuating time: 1 millisecond.
Contact bounce: 1 millisecond.
Actuating rate: Depending on drive can follow up to 400 cycles per second.

APPLICATIONS

- Water-current meter: activating magnet mounts to propeller blade.
- Valve-position indicator: activating magnet, mounted on valve, triggers switch.
- Mechanical-movement monitoring; activating magnet mounts on moving machinery.

The magnetically operated switch assembly, Catalog Number 610F2F-1, includes:

- Exclusive construction of the patented WATERMATE™ electrical connector permits underwater plugging and unplugging with electrical power de-energized.
- Pressure rated up to 5,000 psi or equivalent to maximum 11,000 feet of seawater.
- Pressure balanced for easy engagement and disengagement in high-pressure environments.
- Body is specially formulated neoprene rubber. Contacts are beryllium copper.

Series 41 Penetrators



APPLICATIONS

The Series 41 Penetrators are suitable where a watertight electrical penetration is required through a bulkhead.

CONSTRUCTION

Series 41 Penetrators consist of the penetrator stainless steel body, a length of molded cable on the high-pressure side and leads on the low-pressure side. Series 41 Penetrators feature an internal "waterstop" construction which prevents wicking of water through the penetrator leads, even if the molded section is cut completely through.

This unique construction is pressure rated up to 20,000 psi or maximum 45,000 feet of seawater.

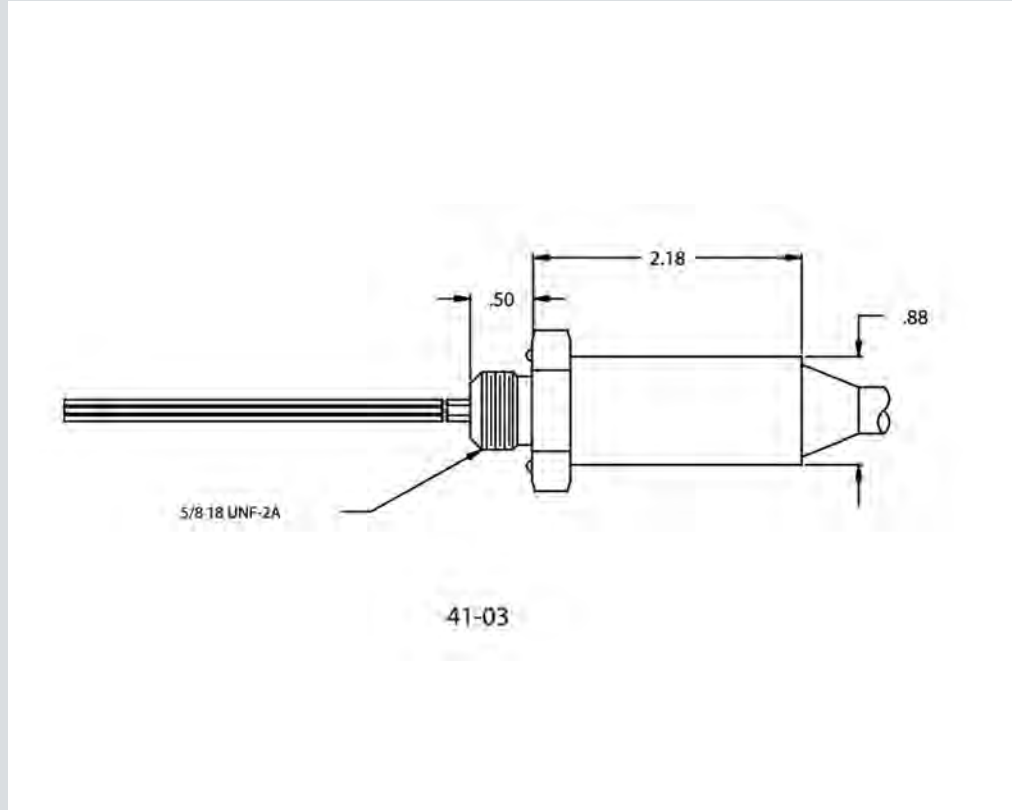

Model	No. of Circuits	L ±1/32 In.	H ±1/32 In.	A ±1/32 In.	T	O	M ±1/32 In.	Wire Size AWG
41-02	2	1.75	.75	.75	7/16-20 NF	2-014	.50	16
41-03	3	2.19	1.13	.88	5/8-18 NF	2-019	.50	16
41-04	4	2.19	1.13	.88	5/8-18 NF	2-019	.50	18
41-06	6	2.38	1.25	1.13	7/8-14 UNF	2-021	.50	18
41-08	8	2.38	1.25	1.13	7/8-14 UNF	2-36	.50	18
41-12	12	3.13	1.50	1.25	1-14 UNF	2-136	.88	18

Unless otherwise specified dimensions are nominal.

Series 41R Right Angle Penetrators

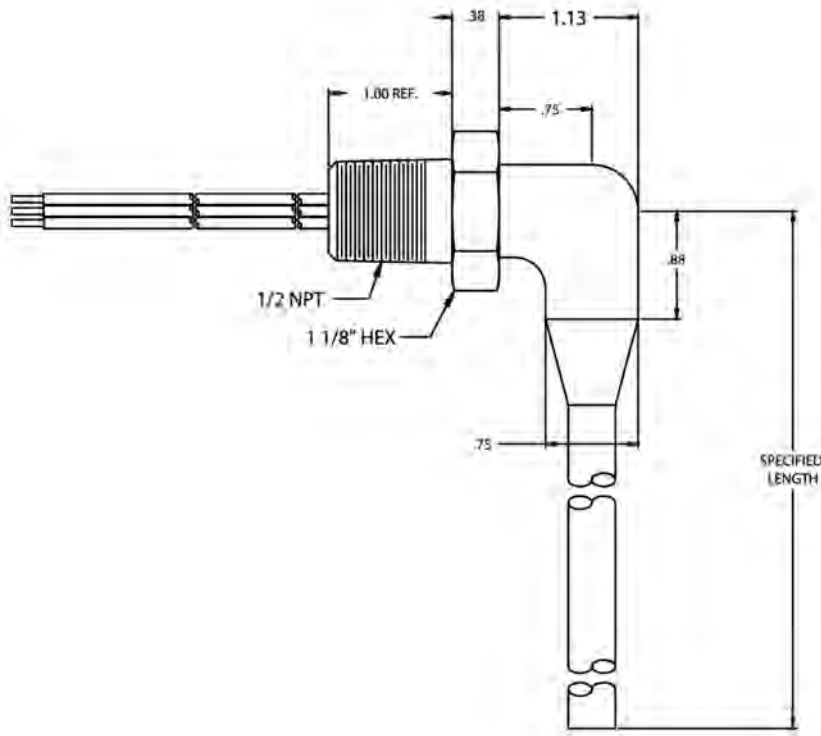

ELECTRO OCEANIC

SPECIALS

Modification of the standard design can be supplied to meet specific applications.

OPTIONS AND SPECIALS

To fit the wide range of possible applications, the 4iR Series Penetrators are available with a broad selection of options, as follows:

- **Body:** Stainless steel is standard; other materials options.*
- **Thread:** Other thread sizes with length as required.*
- **Wire Length:** The wire length on the high or low pressure side can be made as long as desired.*
- **Wire Gauge:** See table on page __.*
- **Termination:** Any compatible connector or junction box may be molded to the cable.*
- **Number of Wires:** Designs are available for up to 168 conductors per penetrator.*

*Optional at extra cost

Model	No. of Circuits	L ±1/32 In.	H ±1/32 In.	M ±1/32 In.	T In.	H In.	A In.	C Max Wire Size	Wire Size AWG
41R-02	2	.88	1.13	1.0	.50	1.13	.75	14	18
41R-03	3	.88	1.13	1.0	.50	1.13	.75	14	15
41R-04	4	.88	1.13	1.0	.50	1.44	.75	16	8
41R-06	6	1.25	1.25	1.0	.75	1.44	.75	16	8
41R-08	8	1.25	1.25	1.0	.75	1.44	.75	18	5
41R-10	10	1.50	1.19	1.31	1.0	1.25	1.38	18	3.5
41R-12	12	1.50	1.19	1.31	1.0	1.25	1.38	18	3.5

Unless otherwise specified dimensions are nominal.

Junction Boxes



The Series 84 Neoprene-molded, multiple-circuit junction box is a flexible, reliable means for:

- Patching power or instrumentation underwater
- Electrical bussing

WATERMATE™ construction permits plugging or unplugging underwater de-energized, with minimum insulation resistance of 100 megohms at 500 VDC contact to contact or contact to water. Hi-Pot specification is 1200 VDC.

Pressure rated to 20,000 psi.

Available with or without molded cable and connector/penetrator options.



Series 54 Junction Boxes are also available. Dummy plugs (with "D0" Suffix) can be installed in unused positions so other receptacle positions may be used. Circuit variations are limited only by user's dimensional requirements and the total number of conductors entering the Junction Box.

Junction Boxes may be molded to virtually any underwater cable including armored types. Pressure rated to 20,000 psi or maximum 45,000 feet of seawater, Series 54 Junction Boxes eliminate the need for expensive water-blocked cable.

To order, consult factory with specific design requirements.

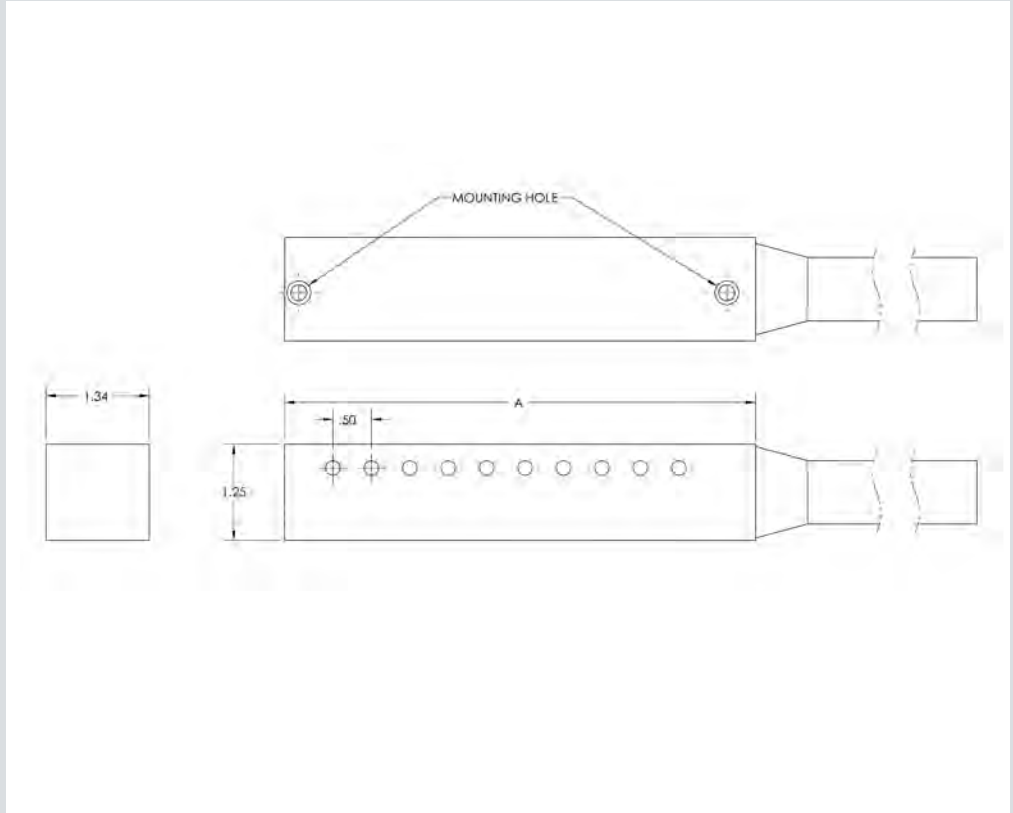

Model	No. of Circuits	Amps Per Contact	Wire Size AWG	A In.	Mates With
84E6F	6	15	16	5.81	All 51E1M-1
84E7F	7	15	16	6.50	
84E8F	8	15	16	7.38	
84E9F	9	15	16	7.88	
84E10F	10	15	16	8.56	
84E11F	11	15	16	9.25	
84E12F	12	15	16	10.13	
Model	No. of Circuits	Amps Per Contact	Wire Size AWG	A In.	Mates Model
84F12F	12	7.5	18	5.81	All 51F1M-1
84F14F	14	7.5	18	6.50	
84F16F	16	7.5	18	7.38	
84F18F	18	7.5	18	7.88	
84F20F	20	7.5	18	8.56	
84F22F	22	7.5	18	9.25	
84F24F	24	7.5	18	10.13	

Unless otherwise specified dimensions are nominal.

Series 58 Locking Sleeves

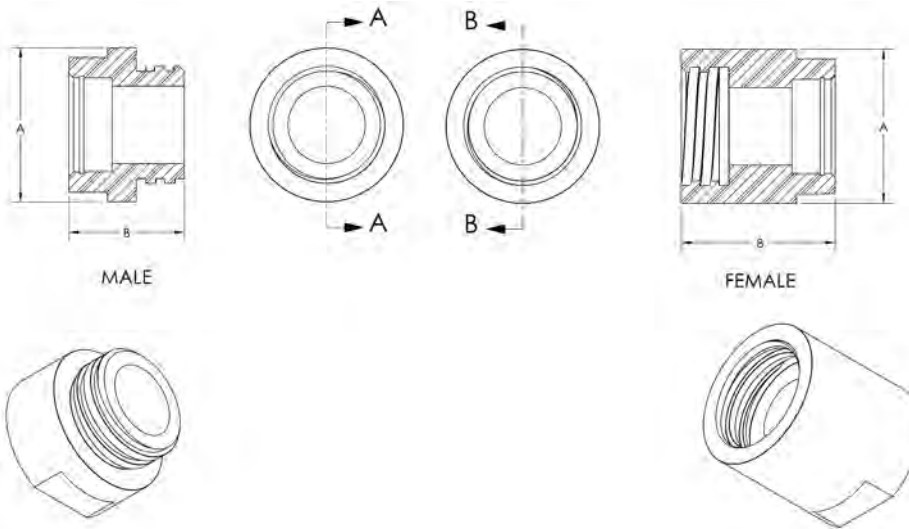

Locking sleeves are not necessarily needed for proper functionality of the E.O. connectors. However, our B series of plugs and receptacles have been designed to accept the use of a locking sleeve. These sleeves provide additional strength and assurance that the connectors will not become disengaged. As a standard our locking sleeves are Delrin but other materials are available by request.

Part Number	Dimension Table		Body O.D.
	A	B	
58TF8-2	2"	1.5"	1"
58TM8-2	2"	1.375"	1"
58TF10-2	2"	1.5	1.25"
58TM10-2	2"	1.375"	1.25"
58TF16-2	3"	3"	2"
58TM16-2	3"	2.75"	2"
58TF16-2B	3"	4"	2"
58TF20-2	3.5"	3.563"	2.5"
58TM20-2	3.5"	3.938"	2.5"

Application Table								
58TF8-2	58TM8-2	58TF10-2	58TM10-2	58TF16-2	58TM16-2	58TF16-2B	58TF20-2	58TM20-2
15	0.65	0.68	1.95	0.31	3.19	2.75	2.12	0.68
16	0.65	0.68	2.12	0.38	---	---	---	0.68
20	0.77	0.79	2.31	0.38	3.97	3.24	2.90	0.79
24	1.02	1.04	2.66	0.38	4.50	3.87	3.25	1.05
32	1.52	1.54	3.50	0.38	5.13	4.50	4.59	1.55

Unless otherwise specified dimensions are nominal.

Miniature Connectors Series 56



APPLICATIONS

The Series56 is specifically designed to meet the need for a fluid-immersed, instrumentation-quality, multiconductor electrical connector. As in all Series 50 products, the 56 is based on the proven, exclusive, WATERMATE™ principle. This permits plugging underwater, with insulation resistance guaranteed to be greater than 100 megohms. Electrical integrity of all connectors is preserved to full ocean depths. The Series 56 features the following characteristics:

MINIATURE

The contact size has been reduced with no loss of current-carrying capacity

LOW CONTACT RESISTANCE

The female connector employs a closed entry beryllium copper contact for low contact resistance and low noise. Contact resistance is in the order of 5 milliohm and repeatable.

MODULAR CONSTRUCTION

The series is designed for complex interconnections and branching, permitting an almost limitless number of input-output combinations.

The connector comes in 1, 2, 3, 4 & 8 circuit modules. 2, 4 & 8 circuit connectors are available in "universal" (combination male and female) designs. In the 1, 2, 3, 4 & 8 circuit designs there are male and female connectors.

The Series 56 features a conical entry section to ease blind engagement underwater. The universal feature completely eliminates polarization problems.

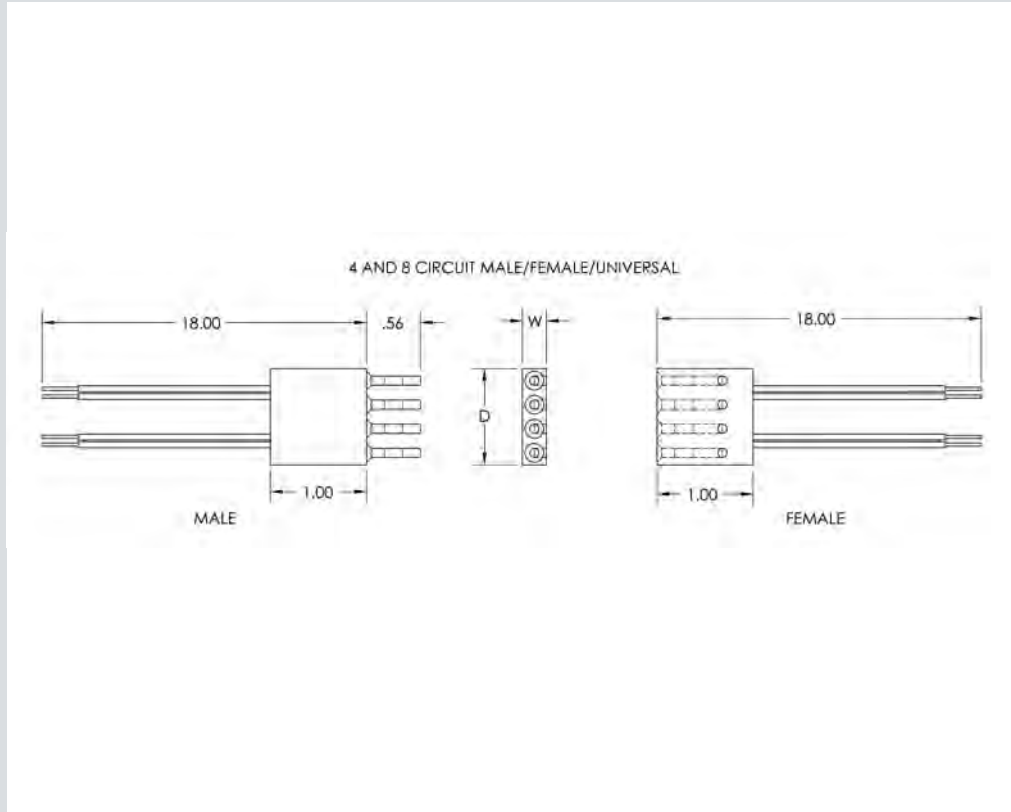

Model	No. of Circuits	No. of Pins or Sockets			Max Volts	Face Style	Amps per Connector (Max.)	Wire Size AWG	B In.	D In.	L In.	Mates With
		M	F	U								
56B1 M or F-1	1	1	1		230	Flat	7.5	18	.25	1.56	1.00	56B1 M or F-1
56B2 M or F-2	1	2	2		230	Offset	7.5	18	.50	1.64	1.08	56B2 M or F-2
56B2 M or F-1	2	2	2		230	Flat	7.5	18	.50	1.64	1.08	56B2 M or F-1
56B2 U-1	2	2		1/1	230	Flat	7.5	18	.50	1.64	1.08	56B2 U-1

Unless otherwise specified dimensions are nominal.

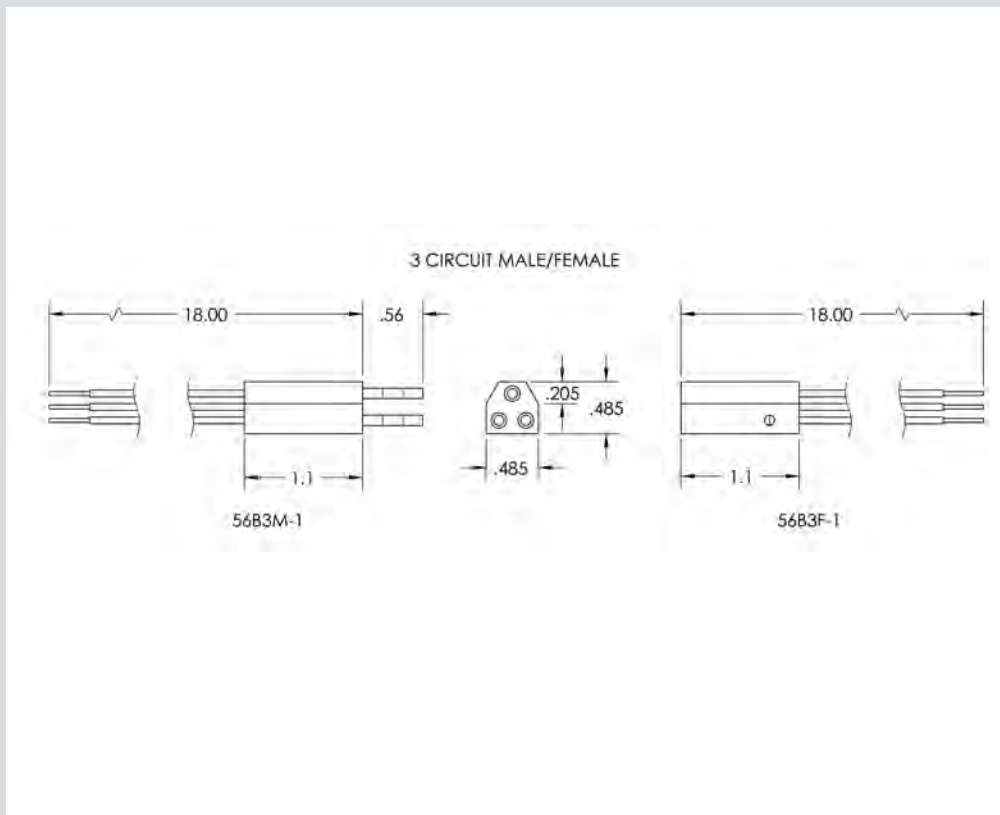

GENERAL SPECIFICATIONS

- Exclusive construction of these patented WATERMATE™ electrical connectors permits underwater plugging and unplugging with electrical power de-energized.
- Pressure rated up to 20,000 psi or maximum 45,000 feet of seawater.
- Pressure balanced for easy engagement and disengagement at high pressure.
- Body is specially formulated neoprene rubber. Contacts are beryllium copper.
- Add DO to base model number for dummy connector, all circuits open.

Add DS to base model number for dummy connector, both circuits shorted.

- Standard leads are #18 AWG – 1 conductor Hypalon insulated wire. Connectors can be supplied on 2 conductor cords as specials.

Model	No. of Circuits	No. of Pins or Sockets	Max Volts	Circuits per Pin or Socket	Amps per Connector	Wire Size AWG	D In.	W In.	Mates With
56B3 M or F-1	3	3	230	1	7.5	18	*	*	56B3 M or F-1
56B4 M or F-1	4	4	230	1	7.5	18	1.0	.25	56B4 M or F-1
56B4 U-1	4	2/2	230	1	7.5	18	1.0	.25	56B4 U-1
56B8 M or F-1	6	8	230	1	7.5	18	2.13	.26	56B8 M or F-1
56B8 U-1	8	4/4	230	1	7.5	18	2.13	.26	56B4 U-1

Unless otherwise specified dimensions are nominal.

WP Series Waterproof Connectors



DESCRIPTION

The WP and WPS Series are transfer molded from the same specially compounded neoprene formula used with underwater pluggable line of connectors. All WP and WPS connectors are vulcanized directly to the cable to provide a positive seal at all pressures up to 20,000 psi.

QUALITY ASSURANCE

WP and WPS connector series are designed to meet the highest standards of reliability for this type of connector.

TYPICAL APPLICATIONS

Underwater instrumentation and control systems – underwater cameras – underwater lighting systems – underwater habitats – diver communications.

DUMMY PLUGS – Dummy Plugs (Caps) are available for purposes of sealing off connectors when not in use and also when possible environmental exposure could damage the connector. When ordering write "DO" after connector designation.

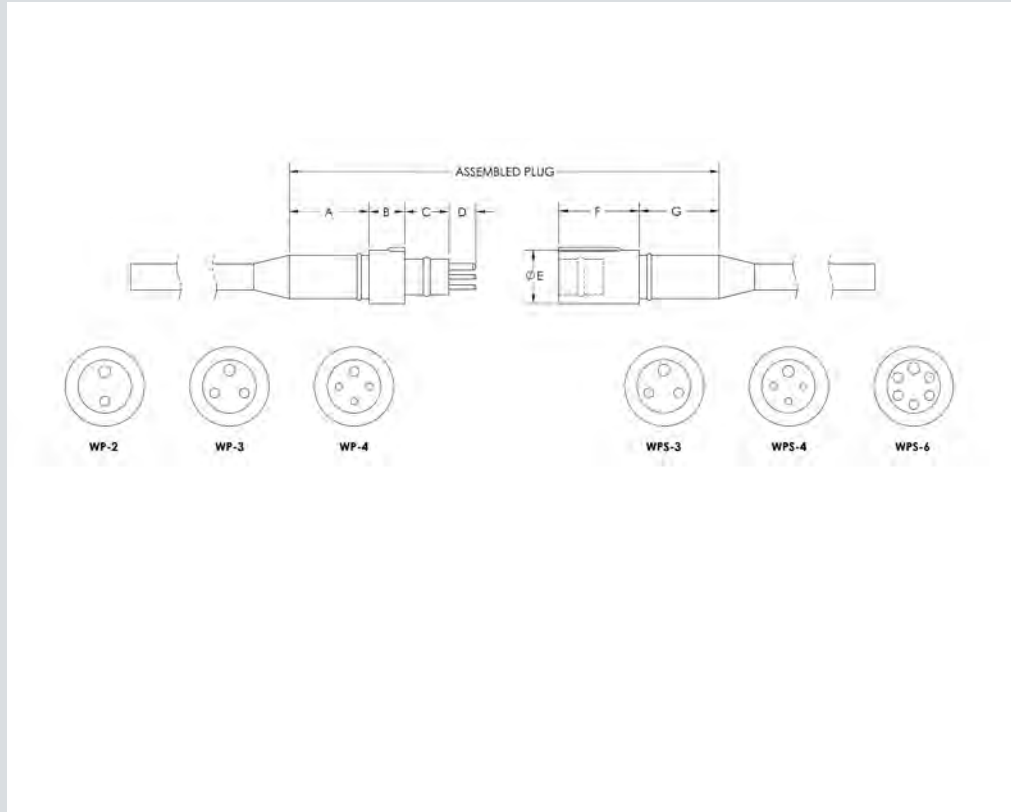



Cooper Interconnect is a leader in production capability for the undersea market. We take great pride in our people, equipment, and the procedures that control the design, manufacturing and testing process. This pride has been earned through our proven record of accomplishment. We blend the ability to operate in small research lots with high volume production capability that is mandatory in developing cost-effective solutions.

Cooper Interconnect's production-related capabilities include:

COMPONENT FABRICATION

- NC mill and lathe machining
- Transfer and compression molding
- Gold plating

GLASS SEALING

- Microprocessor-controlled conveyor furnace system providing four-zone control of process environments
- Chemical processing line and cleaning systems
- Vacuum oven
- Chemical and metallurgical test and analysis equipment
- High-sensitivity helium leak detector

CABLE ASSEMBLY AND TERMINATION

- High speed planetary machine
- Strength member termination
- Programmable wire termination equipment
- Pneumatic assembly tools for contacts, terminal lugs and splices
- Automatic wire cutting and insulation stripping
- MIL-STD-2000 soldering
- Braided shield fabrication
- Fiber optic terminations

CABLE MOLDING

- Complete cable molding capability includes transfer and compression presses, compound mixing equipment, vacuum degassing equipment, freezer, curing and post-curing ovens, and heater platens

TESTING

- 10,000 PSI hydrostatic test pressure vessel
- Computer-controlled automatic test stations for IR, DWV and continuity with automatic printout and failure analysis capability
- High-voltage test station
- Tension testing
- Electromagnetic compatibility test facility
- Fiber optic testing

CABLE HANDLING

- Cable reel handling equipment for the transportation of large bulky cable assemblies

Appendices

Ampacity

The Ampacity or current carrying ability of an insulated conductor is determined by the maximum temperature the insulation can withstand without significant degradation for a period of 40 years at standard conditions. The maximum insulation temperature is the conductor temperature at the conductor/insulation interface so the data is usually listed as an allowable Ampacity at a given conductor temperature. The Ampacity of a conductor is therefore a problem of heat transfer.

One source of such data is the National Electrical Code (NEC), which list 40 amps at 90°C for single 12 AWG (3.3 mm)² copper conductors:

If conductors are bundled together into a cable the heat transfer is reduced and thus the Ampacity of each conductor must also be reduced. The standard ambient temperature for the Ampacity rating above was 30°C for the first 3 and 40°C for the last 2. If the ambient temperatures exceed these standard values the Ampacities must also be reduced. There are tables in the NEC for this purpose.

But an underwater vehicle is not a building nor is it expected to last for 40 years. This means that liberties may be taken with the very conservative NEC ratings at no great peril. The insulation degradation process is essentially a chemical process so if the conductor temperature is increased 10°C the life of the insulated conductor is halved. There is, of course, an upper limit to the maximum conductor temperature when the insulation degradation becomes nonlinear. To Cooper Interconnect's knowledge no studies have been made on this aspect conductor temperature when of Ampacity. Cooper Interconnect uses type S0 cable in most of its products and this cable is rated @ 90°C.

There are many other considerations, of course. Water is an excellent heat sink so in-water operation is not usually a problem. Cooper Interconnect has received reports of successful operations in excess of 4x recommended ampacity in fully submerged applications. However, be cautioned that checkout and testing on deck can be a problem if the benefit of in-water operation is factored into the ampacity although heat buildup is relatively slow most of the time and short "overload" periods are usually tolerated. Caution must be exercised if a wire overheats the insulation may be damaged enough to preclude its operation as a voltage insulator.

Because Ampacity is such a complex subject most designers are as cautious as Cooper Interconnect in specifying the Ampacity of the wire and cable in their equipment.

Cooper Interconnect does not guarantee the accuracy of the NEC data. It is up to the customer to determine the correct conductor size and ampacity for his application.

This table summarizes the NEC data:

Conductor ampacities according to NEC guidelines						
AWG	18	16	14	12	8	6
mm ²	0.823	1.31	2.08	3.31	8.37	13.3
circ mils	1620	2580	4110	6530	16510	26240
1 cond	14	20	30	40	70	90
2 cond	7	10	15	20		
3 cond	7	10	15	20		
4 cond	5.6	8	12	16	28	36
6 cond	5.6	8	12	16		
8 cond	4.9	7	10.5	14		
10 cond	3.5	5	7.5	10		
12 cond	3.5	5	7.5	10		
14 cond	3.5	5				
16 cond	3.5	5				
20 cond	3.5	5				
24 cond	3.2	4.5				
32 cond	3					
40 cond	2.8					

GALVANIC SERIES OF METALS & ALLOYS IN SEAWATER

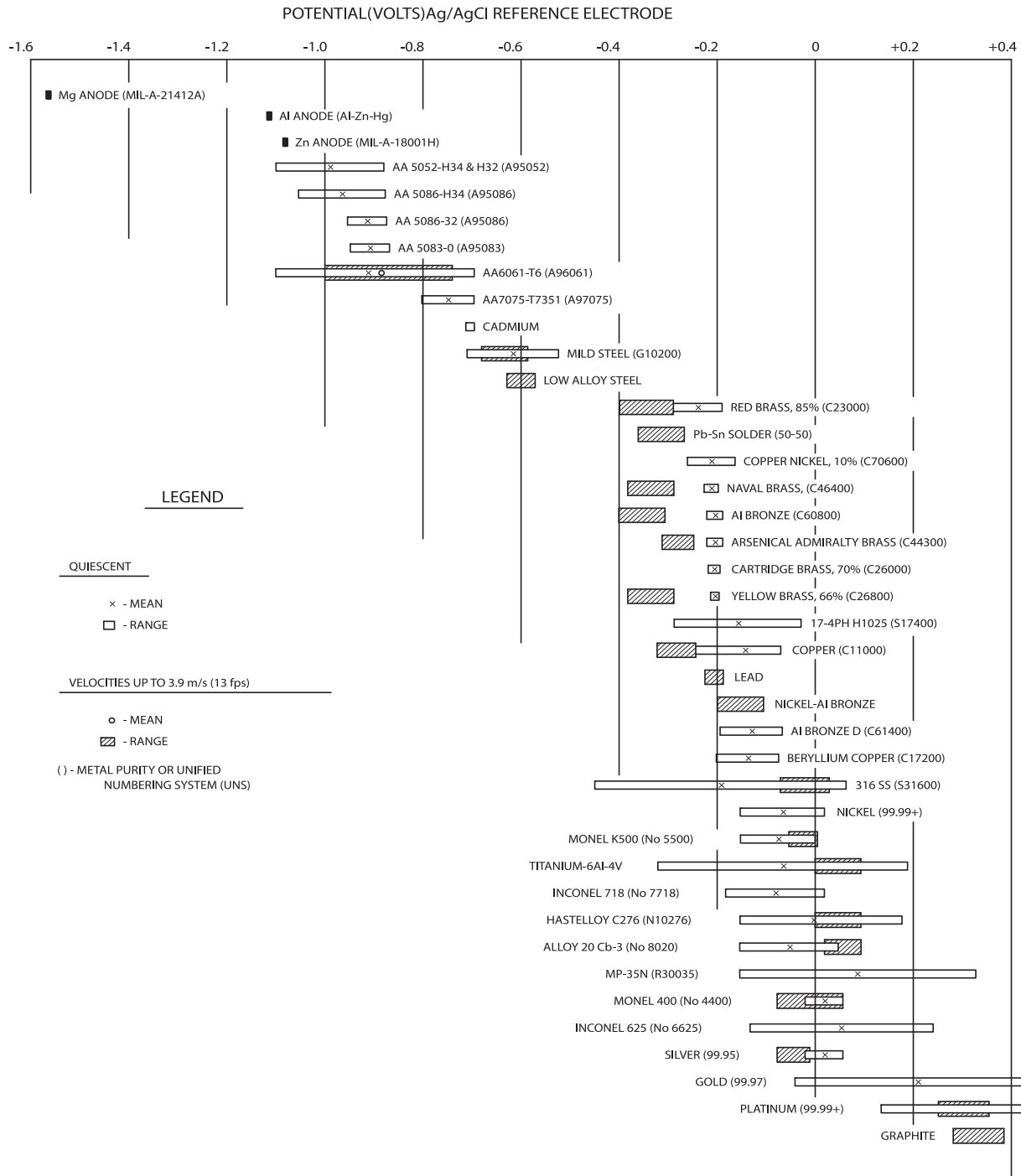

Appendices

Engagement and Disengagement of Connector

Always be sure the power is turned off before either engaging or disengaging a connector. Electrical shocks are easy to get (especially on a wet deck) but hard on people and equipment.

To Engage:

1. Lightly coat the face, sides and sealing surface of the plug with clean Dow Corning DC-4 silicone grease. Be sure there is no moisture on the components.
2. Align the polarizing keyway in plug and receptacle and push to engage the contacts. Push the plug in until the rubber sealing surface and the metal sealing surface touch. A gentle rocking motion will allow trapped air to escape. On the 32 size connectors with many contacts it takes quite a bit of push. Using the coupling nut as an aid to engagement is acceptable but never use a wrench.
3. When the sealing surfaces touch, spin the coupling nut on until it just touches and give it an additional one half turn (1 full turn on 15 size). Caution: The sealing surfaces must be touching for the additional half turn to seal the connector properly. If the coupling nut is used as an aid to engagement, back the nut off completely to obtain visual confirmation of the sealing surface contact. Then spin the nut back on and add the turn. Applying more turns than specified will distort the rubber, possibly resulting in leakage and/or physical damage.

To Disengage:

1. Unscrew the coupling nut completely. Note: After deep initial dives the nut may be loose. This is normal.
2. Grasp the connector body firmly and pull the plug out. Gentle rocking motion may ease pull. Caution: Do not disengage the plug by pulling on the cable; it may break a wire inside the connector.

Receptacle Installation:

The O-Ring sealing surfaces of the receptacles and pressure vessels require an RMS 32 finish, free of scratches, dents, or nicks. Apply a thin coat of clean Dow Corning DC-4 silicone grease to the O-Ring and install the O-Ring in its groove. Remove O-Ring with a nonmetallic object only (such as a wooden tooth pick). For bulkhead receptacles, apply a light coat of oil or antiseize compound to the mounting threads (be careful not to get any on the O-Ring) and assemble the unit. The bulkhead connectors should be torqued to the following specifications:

Shell	Bolt	Torque
15	#10	25 lb-In
16	#10	25 lb-In
20	1/4	45 lb-In
24	1/4	45 lb-In
32	5/16	85 lb-In

For panel mount receptacles, use 4 bolts to hold them in place. The recommended bolt sizes and torques are:

Shell	Torque
15	125 lb-In
16	125 lb-In
20	165 lb-In
24	225 lb-In
32	335 lb-In

The above torques are minimum values which will be acceptable. They may be increased base upon the engineer's knowledge of bolt diameter, thread pitch and the material used for both the bolts and the housing.

Cleaning and Re-use

- A. Clean the plug and receptacle carefully by hand. Use only a bristle brush (no metal allowed) liquid soap and water.
- B. Dry the connection by shaking off excess water then using alcohol to eliminate the remaining water as described below.
- C. Flood the connector with alcohol, then pour it out and allow the connector to air-dry. Caution: Compressed air contains many contaminants such as water, oil and dust and must not be used. Use alcohol only in a well-ventilated area.

Inspection:

- A. Inspect the connector for bent or otherwise damaged pins and corrosion.
- B. Metal sealing surfaces must have a RMS 32 finish and be free of scratches, nicks and dents. This applies to both O-Ring sealing surfaces and connector sealing surfaces.
- C. The rubber sealing surfaces must be free of cuts, nicks and tears. Notes: On used connectors, the rubber sealing surface may have an impression of the metal sealing surface on it. This is normal.
- D. The cable and rubber-molded plug must be free of cuts, tears and separations. Carefully inspect the rubber condition near the metal shell. Tears are common here, caused by using the connector in a bent position or using it as a handle.
- E. When the connectors are being re-used, remember to always use new O-Rings in the receptacles and to inspect the threads of the coupling nut for the presence of dry-film lubrication use to prevent galling of the metal. A light coat of "Molyube" may be used if necessary.
- F. In several instances, Cooper Interconnect recommends using a thin (or Light) coat of silicone grease. It is of the utmost importance to use silicone grease sparingly. In small quantities it is your O-Ring and your connectors' best friend. In large quantities it is your O-Ring and your connectors' worst enemy. Light films reduce friction and allow the components to work as they are designed. Larger quantities create the equivalent of a "Hydraulic Lock" and completely destroy the function of the O-Ring and/or connector.

Cooper Interconnect's Subsea Connectors are manufactured at

750 West Ventura Boulevard
Camarillo, CA 93010
P: 805-484-0543
F: 805-987-5062

4758 Washington Street
LaGrange, NC 28551
P: 252-566-3014
F: 252-566-9337

Cooper Interconnect

222 Williams Street
Chelsea, MA 02150
P: 617-889-3700
F: 617-889-6980

Cooper Interconnect

23 Front Street
Salem, NJ 08079
P: 856-935-7560
F: 856-935-0102

www.cooperinterconnect.com
email info@cooperinterconnect.com

Cooper Interconnect is a trademark of Cooper Industries, Inc.
©2012 Cooper Industries, Inc.

Cooper Industries, Ltd.
600 Travis, Ste. 5800
Houston, TX 77002-1001
P: 713-209-8400
www.cooperindustries.com